

General Specifications

Data Acquisition Unit MW100



GS 04M10B01-01E

Product Overview

The MW100 is a powerful general-purpose data acquisition instrument. Whether as a standalone or connected to a PC, the MW100 offers a flexible data acquisition solution. Designed under the concept of "Smart Logging – Anytime, Anyplace," the MW100 offers the following features.

In a wide range of temperature: Guaranteed operating temperature range: -20-60°C (or -20-50°C when using output modules)

A wide variety of network functions: HTTP, FTP, DHCP, SNTP, E-mail, and others.

Long duration data saving: CF (compact flash) card of up to 2 GB can be used.
Continuous data acquisition on 60 channels/100 ms possible for approximately ten days with a 2-GB card, or three months on 60 channels/1 s.

High speed measurement: 10 channels/10 ms, or 60 channels/100 ms (with a single unit).

Reinforced insulation: Between input terminal and case (reinforced insulation)
3700 Vrms (1 minute), 600 Vrms/VDC (continuous)
Only when MX110 is used as the input module.

Multi-interval: Three different measurement intervals can be mixed in a single unit (measurement intervals set for each module separately).

Flexible system configuration: Modular construction allows assembly of a single unit using only the needed I/O modules.

Variety of inputs/outputs: Modules can be combined to support the following I/O signals.

- Input types
 - DC voltage, thermocouple, RTD (3- or 4-wire), DI, strain, and resistance
- Output types
 - Contact, DC voltage, DC current, pulse width modulation output

MATH functions: Measurement and various kinds of computation can be carried out simultaneously on the MW100.

Web function: A Web browser (Internet Explorer 5.0 or later) can be used for settings and real time monitoring. Files can be easily transferred.

AC/DC power supply support: In addition to the AC power model, a DC power model (12 V-28 V) is included in the lineup.

MW100 Main Unit Configuration

The three components of the MW100 (the main module, input/output modules, and the base plate) can be combined to create custom measuring systems. The assembled unit can be used as-is in a standalone configuration, or rack-mounted using DIN rails. DIN rail mounting is made easy with the DIN rail mounting bracket (comes standard with the base plate).

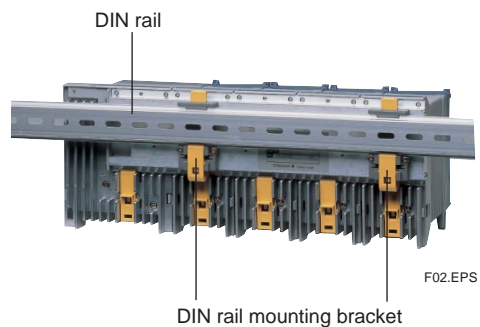
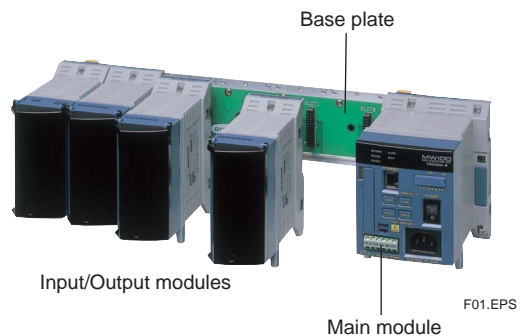

<Main Module> MW100

This is the engine that controls data acquisition. The power supply section, Ethernet port, record START/STOP key, CF (compact flash) card slot, and other components reside here. Measured data is stored in the CF card via the SRAM of the main module (which is backed up by battery, lasting for approximately ten years at room temperature). Up to six input/output modules can be combined in a single main module. Any combination of type or number of these six input/output modules can be used.

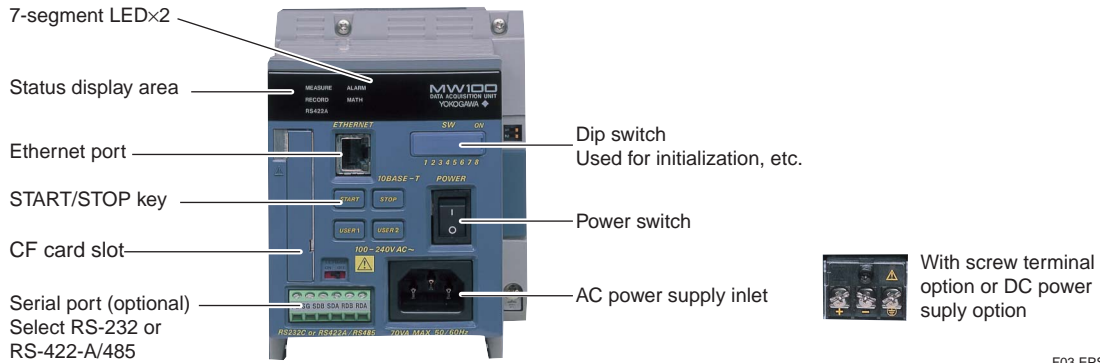

F03.EPS

<Input/Output Module> MX110, MX112, MX115, MX120, MX125

• Four-Channel High-Speed Universal Input Module (MX110-UNV-H04)

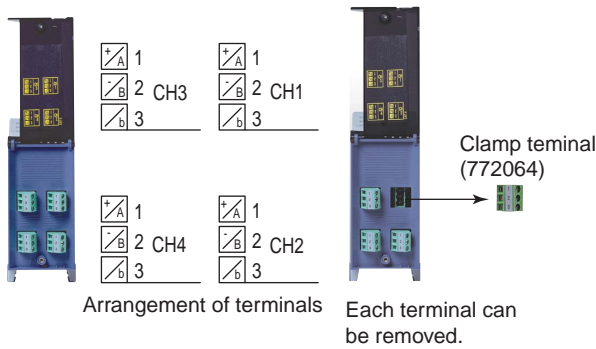

F04.EPS

• Ten-Channel Medium-Speed Universal Input Module (MX110-UNV-M10)

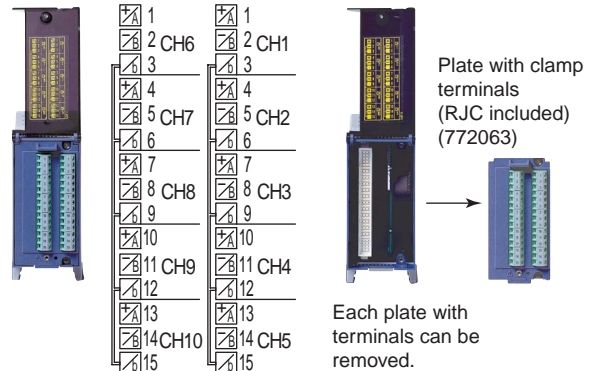

F05.EPS

• Six-Channel Medium-Speed 4-Wire RTD and Resistance Input Module (MX110-V4R-M06)

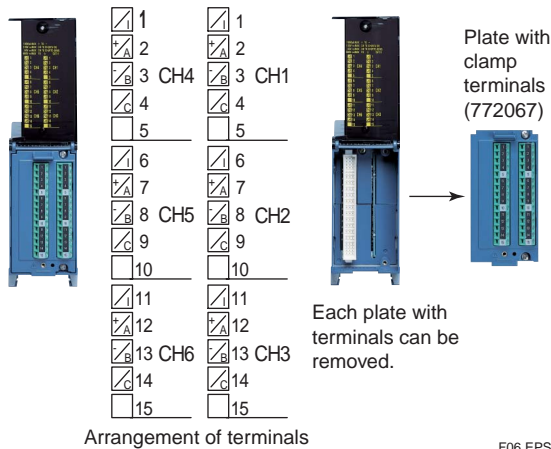

F06.EPS

• Four-Channel Medium-Speed Strain Input Module (built-in bridge resistance of 120 Ω) (MX112-B12-M04)

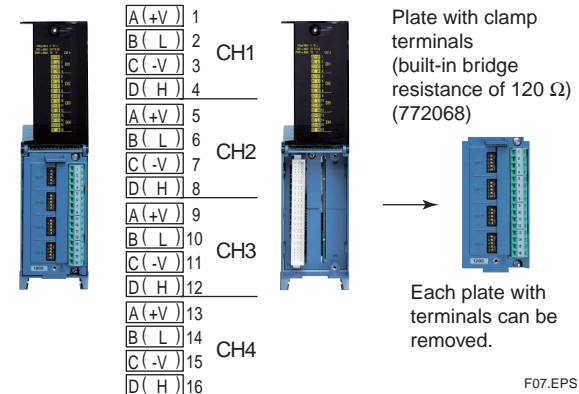

F07.EPS

Arrangement of terminals

Gauge connection methods and DIP switch settings

Gauge connection methods	Switch settings				
	No.1	No.2	No.3	No.4	No.5
Single-gauge (2-wire)	ON	ON	ON	OFF	OFF
Single-gauge (3-wire)	ON	ON	OFF	ON	OFF
Adjacent-side two-gauge	ON	ON	OFF	OFF	ON
Opposed-side two-gauge	ON	OFF	ON	OFF	ON
Four-gauge	OFF	OFF	OFF	OFF	ON

• **Four-Channel Medium-Speed Strain Input Module (built-in bridge resistance of 350 Ω) (MX112-B35-M04)**

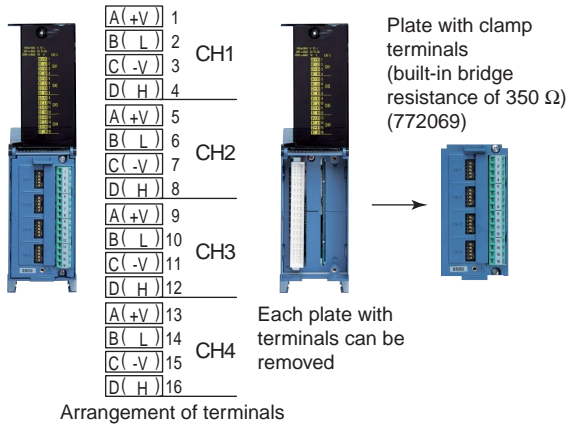

F08.EPS

• **Four-Channel Medium-Speed Strain Input Module (For connection with an external bridge head and strain gauge type sensor, NDIS connector) (MX112-NDI-M04)**

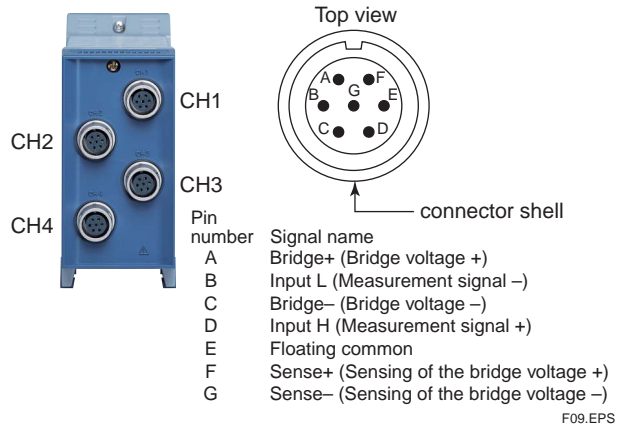

F09.EPS

• **Ten-Channel High-Speed 5 V Digital Input Module (MX115-D05-H10)**

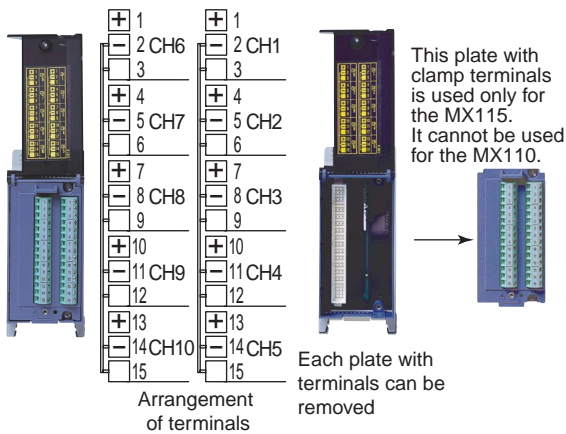

F10.EPS

• **Ten-Channel High-Speed 24 V Digital Input Module (MX115-D24-H10)**

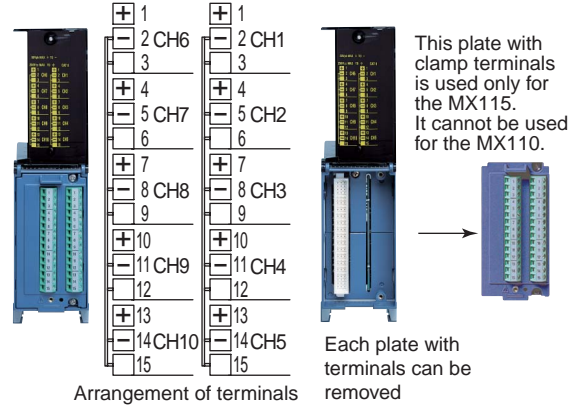

F11.EPS

• **Eight-Channel Medium-Speed Analog Output Module (MX120-VAO-M08)**

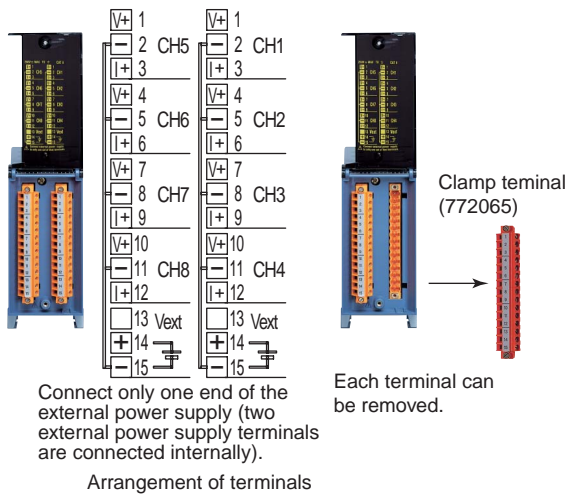

F12.EPS

• **Eight-Channel Medium-Speed PWM Output Module (MX120-PWM-M08)**

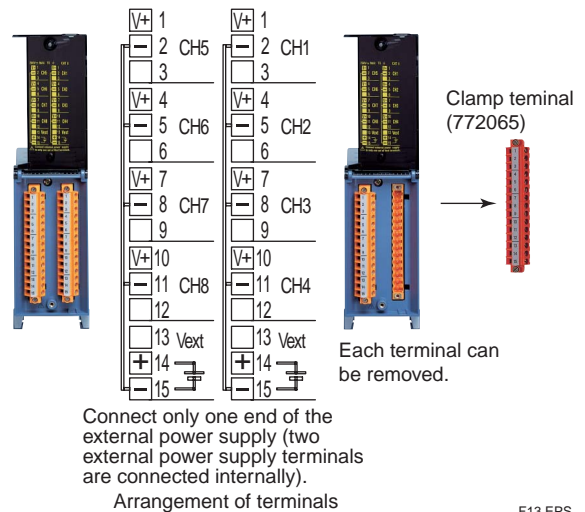

F13.EPS

• **Ten-Channel Medium-Speed Digital Output Module (MX125-MKC-M10)**

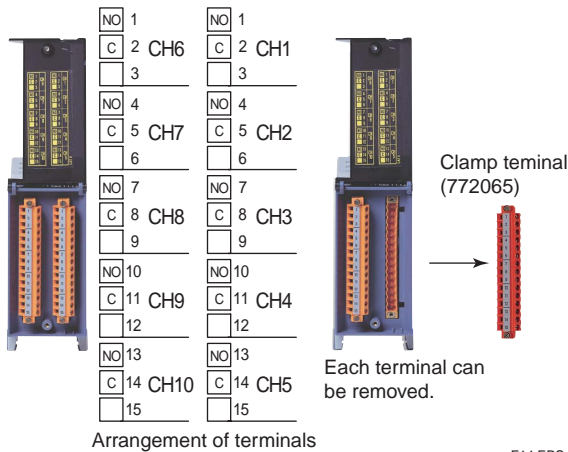

F14.EPS

<Base Plate> **MX150**

The main module and input/output modules are connected using connectors on base plates. The following six types of base plates are available:

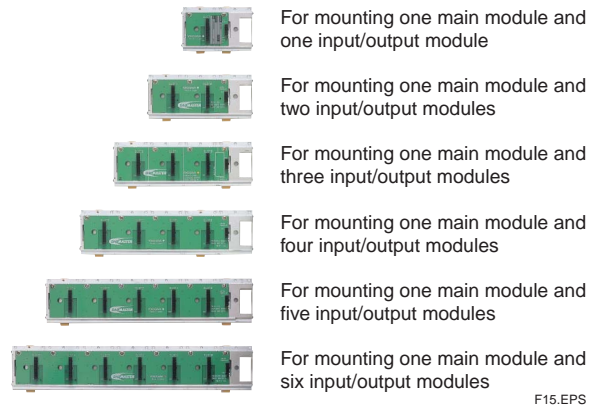

F15.EPS

When used for the MW100, you must replace the attachment with the one that comes standard with the MW100.

<Other Accessories>

• **Screw terminal plate (M3)**

A screw terminal plate (M3) is available for the Ten-Channel Medium-Speed Universal Input Module (MX110-UNV-M10) and the Ten-Channel High-Speed Digital Input Module (MX115-Dxx-H10). The clamp terminal plate is removed from the MX110-UNV-M10 or MX115-Dxx-H10 and replaced with the screw terminal plate.

You can also specify an option code to order versions of the MX110-UNV-M10 and MX115-Dxx-H10 that are shipped without the clamp terminal plates. If you plan to use only the screw terminal plate and do not need the clamp terminal plate, please specify MX110-UNV-M10/NC or MX115-Dxx-H10/NC when ordering.

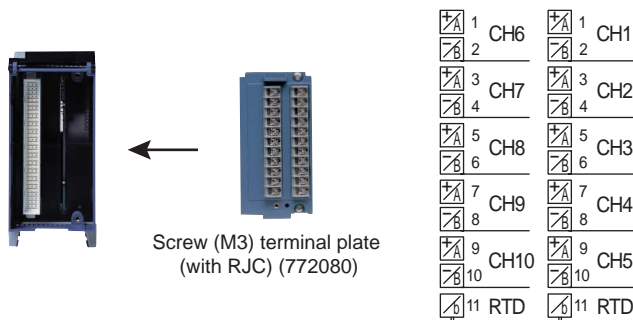

Arrangement of terminals

There are two b terminals for three-wire RTD. When connecting 3 or more RTDs, use them in common.

Attach the screw terminal plate (model 772080) in place of the clamp terminal plate.

F15-2.EPS

• **Screw Terminal Block (M4)**

A separate screw terminal block (M4) is available for the Ten-Channel Medium-Speed Universal Input Module (MX110-UNV-M10) and Ten-Channel High-Speed Digital Input Module (MX115-Dxx-H10).

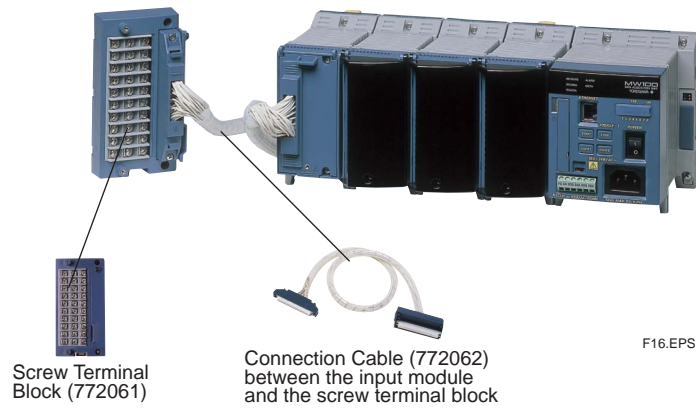

Remove the plate with clamp terminals from the MX110-UNV-M10 or the MX115-Dxx-H10. Then, connect each module with the screw terminal block (772061) by means of the connection cable (772062).

Option code can be added to the MX110-UNV-M10 and the MX115-Dxx-H10 to indicate whether or not the plate with clamp terminals is included at the time of delivery. If the user requires only the screw terminal block and not the clamp terminals, specify either the MX110-UNV-M10/NC or the MX115-D05-H10/NC.

• **Connector Cover for Base Plate**

A connector cover is available for a vacant slot, into which a module is not inserted.



■ Basic System Configuration

A connection with the PC is required for entering settings on the MW100 and for real time data monitoring. For independent data acquisition on the MW100 (by pressing the START/STOP key on the main unit), the connection to the PC is not necessary once settings have been entered.

(1) When Using Ethernet (Comes Standard):

Entry of settings*1 and real time monitoring can be carried out using a browser (Internet Explorer). Also, use of the FTP and SNTTP functions, and data acquisition and settings through communication commands are also possible. Note that the PC, hub, and Ethernet cables must be supplied by the user.

*1: Yokogawa provides dedicated PC software for entry of initial settings.

• PC and MW100 in a One-to-One Connection

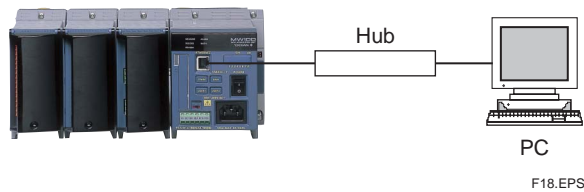

• PC and MW100 in a One-to-N (Multiple MW100s) Connection

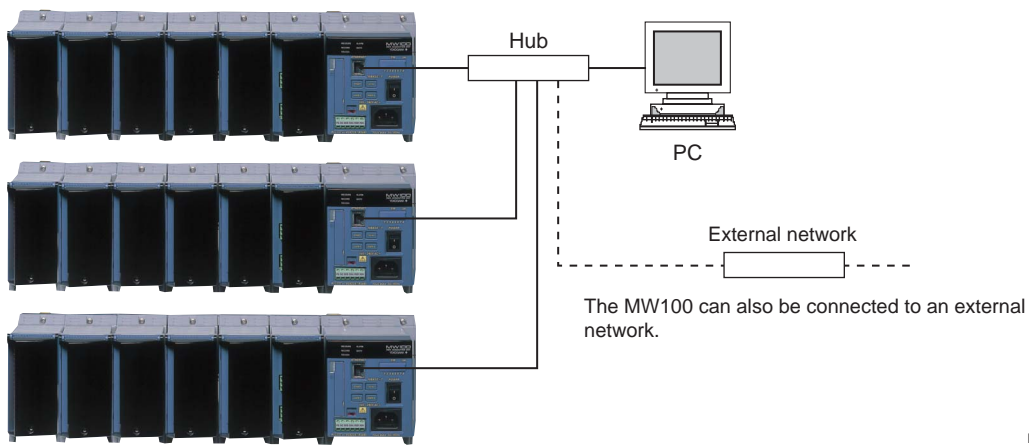

• PC and MW100 in an N (Multiple PCs)-to-One Connection

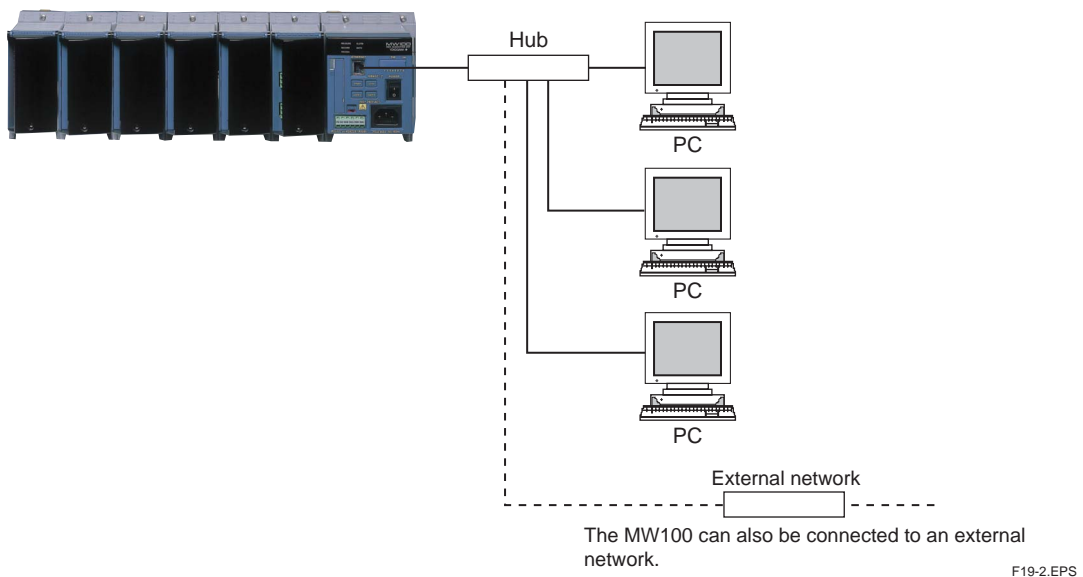

(2) When Using Serial Communications (RS-232 and RS-422A/485, Optional):

Data acquisition and settings are enabled through communication commands. The PC and connection cables must be supplied by the user.

(3) Definitions of unit no., slot no. and channel no.

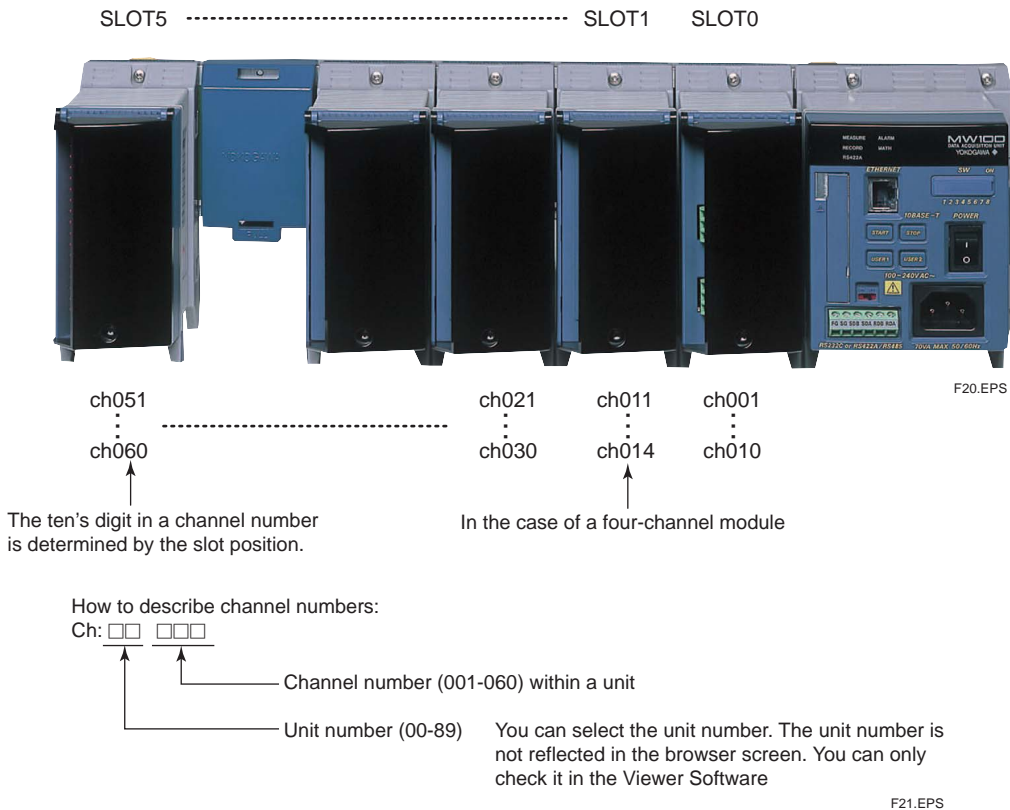

Functional Overview

- Input types: DC voltage, temperature (TC, 3-wire RTD, 4-wire RTD), digital (non-voltage contact, open collector, level (5 V logic, 24 V logic)), strain, resistance
- Output types: "A" contact (SPST), DC voltage, DC current, PWM (pulse width modulation)
- Number of measurement points: Up to 60 channels per unit.
- Number of output points: Up to 60 channels per unit.
- Measurement interval: The shortest measurement interval is 10 ms. It depends on the types of modules and number of measurement points.
- Multi-interval: Three measurement intervals can be set for each module within a unit.
- MATH function (computation): To be performed in the main module (optional).
- Display: To be performed by a web browser
- Settings: To be performed by a web browser
- Save: To the CF card
- Interface: 10 Base-T Ethernet

Data acquired on the input module is saved on the main module's CF card. Data recording can be started and stopped using the START/STOP key on the main module, or by a command from the PC. Also, an output module can be used for contact output upon detection of alarms, transmission output of measured values, output of arbitrary values, and other functions.

The MW100 allows settings to be entered (certain settings excluded) and measured data to be monitored using a browser (Internet Explorer 5.0 or later). (Requires a browser with Java VM and Java Script installed.) WebDAV and FTP functions are also included, enabling acquisition of files from the MW100's CF card onto the PC.

■ Hardware Specifications

Common Specifications

• Normal operating conditions

- Operating temperature range*1: -20-60°C (when not using the MX120 or MX125 output modules)
-20-50°C (when using the MX120 or MX125 output modules)
- Operating humidity range*2, 3: 20-80% RH for -20-40°C
10-50% RH for 40-50°C
5-30% RH for 50-60°C
- Rated power supply voltage: AC power supply: 100-240 VAC (with or without AC adapter)
DC power supply: 12-28 VDC
- Range of operating power supply voltage: AC power supply: 90-250 VAC (with or without AC adapter)
DC power supply: 10-32 VDC
- Power supply frequency: 50 Hz ±2%, 60 Hz ±2% (AC power supply)
- Power consumption: Approximately 70 VA max when six modules are used (using AC power supply)
Approximately 35 VA max when six modules are used (using DC power supply)
Approximately 70 VA max when six modules are used (using DC power supply and AC adapter)
- Vibration: 10-60 Hz, 0.2 m/s² or less
- Shock: Not allowed
- Magnetic field: 400 A/m or less (50/60 Hz)
- Position: Position horizontally with feet down
- Usage location: Indoors
- Operating altitude: 2,000 m or less
- Overvoltage category: II (per IEC61010-1 and CSA C22.2 No.61010-1)
- Measurement category: II (per IEC61010-1 and CSA C22.2 No.61010-1)
- Degree of pollution: 2 (per IEC61010-1 and CSA C22.2 No.61010-1)

*1: Not including operating temperature range specification of accessory AC power cord and AC adapter. The operating temperature range specifications of the AC power supply cord and AC adapter are as shown below.

Suffix code in the model name	Standard applicable to included power cord	Operating temperature
-1D	UL/CSA	-20-60°C
-1F	VDE	-15-60°C
-1R	SAA	-15-60°C
-1Q	BS	-15-60°C
-1H	GB (CCC)	-15-60°C

T01-1.EPS

The operating temperature range of the AC adapter is 0 to 40°C.

*2: The operating humidity range of the AC adapter is 20-80% RH at 0-40°C. (no condensation)

*3: No condensation

• Shipping and Storage Conditions

Environmental conditions for the transportation/storage of equipment from the time of delivery until the start of use, as well as for the transportation/storage when the use of equipment is temporarily suspended.

- Storage ambient temperature: -25-70°C
- Storage ambient humidity: 5-95%RH (or 10-90%RH for the AC adapter)
- Vibration: 10-60 Hz, 4.9 m/s² or less
- Shock: 392 m/s² or less (when packaged)

• Mechanical Specifications (Excluding AC Adapter)

- External dimensions: Approximately 455 (W) × 131 (H) × 159 (D) mm (with six modules installed)
- Weight: Approximately 4.3 kg (total weight with six modules installed)
- Installation method: Desktop/on the floor/Panel mount with DIN rails
- Supported Standards:

CSA	Obtained CSA22.2 No.61010-1, Overvoltage category: II, Measurement category: II, Degree of pollution: 2	
UL	Obtained UL61010B-1 (CSA NRTL/C)	
CE	EMC directive	EN61326 EN61000-3-2 EN61000-3-3 EN55011 Class A Group1
	Low voltage directive	EN61010-1, Overvoltage category: II, Measurement category: II, Degree of pollution: 2
C-Tick	Obtained AS/NZS CISPR11 Class A Group 1	

T01.EPS

Model-Specific Specifications

• **Main Module (MW100)**

Style number: S2

Main functions: Control of the power supply and I/O modules, communications with the PC, and storage of data on the CF card.

Number of maximum connectable input/output modules: 6 (arbitrary for six modules or less)

Measurement interval: 10/50/100/200/500 ms, or 1/2/5/10/20/30/60 s

Note that the configurable measurement intervals differ depending on the modules.

Also, the following limitations apply to the measurement interval and number of measurement channels.

Measurement Interval	Maximum number of measurement channels	Notes
10 ms	10	Modules whose measurement interval is not set to 10 ms or 50 ms can be set to 100 ms or higher.
10 ms and 50 ms mixed	10	
50 ms	30	

T02-1.EPS

Multi-interval (measurement groups): Up to three intervals defined for the input modules can be set.

Synchronization between modules: Synchronized within the same measurement interval (within the same unit)

Synchronization between channels: Synchronized between channels in the same module for the MX110-UNV-H04 and the MX115-Dxx-H10. Channels within the MX110-UNV-M10, MX110-V4R-M06, and M112 input modules are asynchronous due to the scanner type.

Filter function: First-order lag filter can be set on each channel.

Time constant = measurement interval × N, where N is 0, 5, 10, 20, 25, 40, 50, or 100

List of Time Constants

Measurement interval (sec.)	Time Constant (sec.)						
	N=5	N=10	N=20	N=25	N=40	N=50	N=100
0.01	0.05	0.1	0.2	0.25	0.4	0.5	1
0.05	0.25	0.5	1	1.25	2	2.5	5
0.1	0.5	1	2	2.5	4	5	10
0.2	1	2	4	5	8	10	20
0.5	2.5	5	10	12.5	20	25	50
1	5	10	20	25	40	50	100
2	10	20	40	50	80	100	200
5	25	50	100	125	200	250	500
10	50	100	200	250	400	500	1000
20	100	200	400	500	800	1000	2000
30	150	300	600	750	1200	1500	3000
60	300	600	1200	1500	2400	3000	6000

T02.EPS

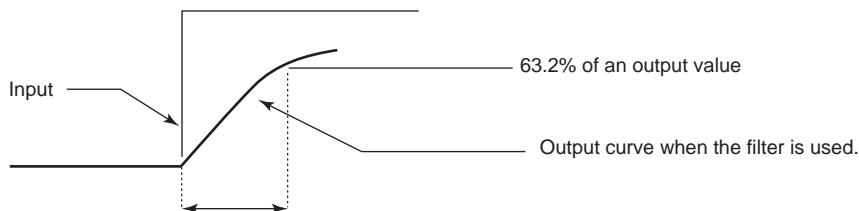

- A time constant described in the above (List of Time Constants).
- Time required to achieve 63.2% of an output value.

F22.EPS

Operation after failure recovery: After recovery from a power failure, the operation before the failure is continued.

User Interface Specifications

Number of keys: 4

Starting (START) and Stopping (STOP) Recording

User function 1 (USER1), user function 2 (USER2)

Start key: Starts measurement, MATH, and recording.

Stop key: Stops measurement, MATH, and recording, and saves data acquisition logs and alarm summaries.

User function keys 1 and 2: Keys can be assigned arbitrarily by the user with the Event/Action function.

Key lock function: All keys can be enabled or disabled at once.

7 segment LEDs: 2

Displays status, operation status, unit number, error occurrence, and other information.

Status LEDs: 5

Illuminated: Indicates measuring, recording, alarm occurrence, computing, and receiving data by serial communications.

Blinking: Recording or computation in progress.

Ethernet status display LEDs: 2

Orange: LINK (connecting), Green: ACT (sending/receiving data)

Input MATH Function (Functions Available from the Main Module without the MATH Option (/M1))

Differential computation between channels:

Differential computation between arbitrary channels (DCV, TC, RTD, DI, strain, resistance)

Linear scaling computation

Possible range for scaling: DCV, TC, RTD, DI, strain, and resistance

Possible scope for scaling: -30000 to 30000

Decimal places: Set between 0 and 4

Units: Can be arbitrarily set using up to six characters

Remote RJC: Specify an arbitrary channel as the RJC input channel and perform computation.

Initial balance (with the MX112 Strain Module):

The initial balance value is measured and set as the 0 point.

Initial balance initialization (with the MX112 Strain Module):

Returns the initial balance value to 0 (the default).

Initial balance reloading (with the MX112 Strain Module):

Reloads the saved initial balance value.

(Reloads the saved initial balance value from the setting value save file.)

Alarm Functions

Channels: Measurement and MATH channels

Number of alarms: Four levels per channel

Alarm types: Upper limit, lower limit, differential upper limit, differential lower limit, rate of change upper limit, rate of change lower limit

Differential upper limit and differential lower limit only available for differential input measurement channels.

Only upper limit and lower limit alarms can be set on MATH channels.

Rate of change alarm intervals: Select an interval from 1 to 32 times the measurement interval.

Only one interval each can be selected for all rate of change upper limit alarms and rate of change lower limit alarms.

Hysteresis: Can be set for each channel (however, fixed at 0 for MATH channels and with rate of change alarms)

Number of relay outputs: 1 to 60 points depending on the number of mounted MX125 Digital Output Modules.

Output mode: Excitation/non-excitation, AND/OR, Hold/Non-hold, reflash alarm

Alarm ACK: If set to Hold using the alarm status or relay output Hold/Non-hold function, the hold status is cleared.

Alarm update interval: 100 ms (not synchronized with the measurement interval)

Digital Output Function (Available Only When the MX125 Digital Output Module Is Installed)

Alarm output: Output of alarms processed in the unit

Communication command output: Output in response to digital output requests from the PC (communication commands)

Output of free space on media: Output when the free space on the CF card is less than the specified time (select 1, 2, 3, 4, or 5 hours), fixed to excitation.

Fail output: Output upon detection of abnormal operation of unit, fixed to non-excitation.

Error output: Output when unit operating normally, but an error occurs, fixed to excitation.

An *Error* refers to a condition in which a module is disconnected or the unit fails.

Output interval: 100 ms (not synchronized with the measurement interval)

Analog Output Function (Available Only When the MX120-VA0-M08 Analog Output Module Is Installed)

- Communication command output: Output in response to analog output requests from the PC (communication commands or browser.)
- Transmission output: Measured values from the input module or computed values are scaled and output.
Output Range: Choose from Two Ranges, 10 V and 20 mA.
- Output upon power ON: Outputs immediately after power turned ON. Outputs the previous value or preset value (selectable) until measurement start or command received.
- Output upon abnormality (Error): Outputs when the input value for transmission output results in an error, when the CPU goes down, and other cases when an error occurs. Outputs the previous value or preset value (selectable).
- Output upon \pm Over: When transmission output is \pm Over, outputs \pm 5% of the set output span.
- Output timing: 100 ms (not synchronized with the measurement interval)

PWM Output Function (Available Only When the MX120-PWM-M08 PWM Output Module Is Installed)

- Communication command output: Outputs pulse width signals in response to output requests from the PC (communication commands or browser).
- Transmission output: Measured values from the input module or computed values are scaled and output.
- Output range (select either 1 ms mode or 10 ms mode) :
1 ms range: Pulse interval: 1 ms-30.000 s, setting resolution: 1 ms
10 ms range: Pulse interval: 10 ms-300.000 s, setting resolution: 10 ms
- Output upon power ON: Outputs immediately after power turned ON. Outputs the previous value or preset value (selectable) until measurement start or command received.
- Output upon abnormality (Error): Outputs when the input value for transmission output results in an error, when the CPU goes down, and other cases when an error occurs. Outputs the previous value or preset value (selectable).
- Output upon \pm Over: When transmission output is \pm Over, outputs \pm 5% of the set output span.
(However, the minimum value is 0%, and the maximum is 100%)
- Output timing: 100 ms (not synchronized with the measurement interval)

MATH Function Specifications (/M1 Option)

- Number of MATH channels
Number of channels for computation: 60 (can also be used as communication input channels)
Number of channels for communication input: 240
- MATH start/stop: Execution of computation starts and stops according to user commands (Event/Action function, communication commands, browser, or START/STOP key).
- Reset/clear computed values:
Executes resetting/clearing of the computed values according to the Event/Action function, or requests via communication commands.
Group reset: The Event/Action function resets, group by group, all MATH channels included in each group.
- Computations: Basic math functions (+, -, \times , \div , power)
Relational operators (>, \geq , =, \leq , <, \neq)
Logical operators (AND, OR, XOR, NOT)
Arithmetic operators (SQR, ABS, LOG, EXP)
TLOG computations (max, min, max-min, average, integration, pulse integration)
CLOG computations (max, min, max-min, average)
Conditional expressions ([EXPR1?EXPR2:EXPR3])
- MATH reference channels: The following types of channels can be incorporated into expressions.
Measurement channels, MATH channels, communication input channels, flag input channels, MATH constants, and broken-line input channels.
- MATH interval: Specify one of the intervals set for multi-interval, then perform the computation.
However, measurement intervals of 10 ms or 50 ms cannot be specified.
- Characters used in expressions: Up to 120 per channel
For communication input channels, a maximum of 8 characters can be used per channel.
- Computation span: When displaying waveforms on the Web, set the upper and lower limit values. The setting range is as follows:

Decimal place setting	Setting range of computation span
0	-9999999-99999999
1	-999999.9-9999999.9
2	-99999.99-999999.99
3	-9999.999-99999.999
4	-999.9999-9999.9999

T02-3.EPS

Computation range: A given result during computation must be within $\pm 3.4 \times 10^{38}$.

Computation output values: Data output by the computation. The output range is as follows:

If the computation does not finish within the MATH interval and a computation is omitted, the previous value is output.

Data Type	Description
-9,999,999-99,999,999	Normal output range
2,147,450,879 (7FFF7FFFh)	Plus over
-2,147,385,343 (80018001h)	Minus over
-2,147,319,806 (80028002h)	Skip

T02-4.EPS

MATH constants: 60

The number of significant digits: mantissa, 5 digits; exponent, 2 digits

Range: -9.9999E+29 to -1.0000E-30, 0, 1.0000E-30 to 9.9999E+29

Communication input channels (channels that can be input as substitutions for numerical values obtained via communication): 300

The number of significant digits: mantissa, 5 digits; exponent, 2 digits

Range: -9.9999E+29 to -1.0000E-30, 0, 1.0000E-30 to 9.9999E+29

Flag input channels: 60

Flag value (0 or 1) can be substituted in computational expressions.

Varies according to the action of the Event/Action function.

Broken-line input channels: 3

The output from the MX120 output modules can be executed according to the broken lines specified on these channels.

Up to 32 points from the start point to a specified time thereafter (in seconds) can be set as conditions for the broken line. Straight lines are interpolated between specified points.

Computation alarm function: Four levels per channel

Upper limit and lower limit types only. No hysteresis function available.

Recording Function Specifications

Main functions: Measured values, computed values, thinned values, setting values, data acquisition log, and alarm summary can be saved to CF card.

Each data file is stored in the following folders (folders automatically created).

Config: Folder for storing the setting value file

Data: Folder for storing the DataN folder

DataN: Folder for storing files containing measured values, computed values, thinned values, the data acquisition log, and the alarm summary. N is automatically incremented from 0 to 9999 every time recording is started.

Supported external media: CF card Type I \times 1 slot

Maximum allowable card size: 2 GB

Measured and Computed Value Recording Function:

Record start/stop: Starts and stops recording to CF card according to the START/STOP key, Event/Action function, communication commands or browser.

Recording operation: Measured values and computed values are recorded in separate files on the CF card. If measured values are divided by group, a separate file is created and saved on the CF card for each group.

Measurement groups: Measurement channels can be divided into up to 3 groups by module.

Write mode: Select a record complete action for each measurement group of Single, Full stop, or Rotate.

Write mode	Action
Single	Save a file of the specified size then stop saving.
Full stop	Save files of the specified size until the CF card is full then stop saving.
Rotate	Continue saving files of the specified size until the CF card is full, delete the oldest files from the storage folder (DataN), then continue saving. Saving does not stop unless requested by the user.

T02-6.EPS

Triggers: Select a record start action for each measurement group of Direct or Trigger.

Trigger mode	Action
Direct	Starts recording to CF card simultaneously with the record start operation.
Trigger	Starts recording to CF card simultaneously with the record start operation, then enters trigger wait mode. After a trigger event occurs according to the Event/Action setting, the amount of data specified as the post trigger and pre trigger amounts is recorded. After recording starts, normally: Post trigger amount = (File size data amount) - (Pre-trigger amount) ...but if the trigger occurs before the pre-trigger amount is saved, Post trigger amount = (File size data amount) - (Already saved pre-trigger amount) Also, if another trigger occurs before the post-trigger amount is saved, it is ignored.

T02-7.EPS

Recording interval: Set the recording interval for each measurement group as an integer multiple of the measurement interval.

- If the measurement interval is 10, or 100 ms; or 1, 2, 10, 20, 30, or 60 s, set a multiple of 1, 2, 5, or 10.
- For a measurement interval of 50 or 500 ms; or 5 s, set a multiple of 1, 2, 4, or 10.
- For a measurement interval of 200 ms, set a multiple of 1, 5, or 10.

File name: Generated automatically in sequence using the date and time (cannot be specified by the user).

Data length: If a trigger is specified in trigger mode, the data length of a single file can be selected for each measurement group as: 10, 20, or 30 minutes; 1, 2, 3, 4, 6, 8, or 12 hours; or 1, 2, 3, 5, 7, or 10 days.

However, it cannot be set so that the file size could exceed 10 Mbyte.

If Direct is specified in trigger mode, the data length of a single file is selected for all measurement groups as: 30 minutes; or 1, 2, 3, 4, 6, 8, or 12 hours; or 1, 2, 3, 5, 7, 10, 14, or 31 days.

However, it cannot be set so that the file size could exceed 10 Mbyte.

Pre-trigger function: If Trigger is selected for the trigger mode, a pre-trigger of 10% intervals relative to 0 to 100% of the data length can be set for each measurement group.

Recording channels: Recording can be turned ON/OFF independently on each channel.

The number of recording channels per second should be around 1500 or less.

EX. 1: Measurement group, 1; recording interval, 10 ms; number of channels, 10.
Measurement group, 2; recording interval, 100 ms; number of channels, 50.
 $(1 \text{ s}/0.01 \text{ s}) \times 10 + (1 \text{ s}/0.1 \text{ s}) \times 50 = 1500 \text{ channels/s}$

EX. 2: Measurement group, 1; recording interval, 10 ms; number of channels, 4.
Measurement group, 2; recording interval, 100 ms; number of channels, 40.
Measurement group, 2; recording interval, 100 ms; number of math channels, 60.
Measurement group, 3; recording interval, 200 ms; number of channels, 10.
 $(1 \text{ s}/0.01 \text{ s}) \times 4 + (1 \text{ s}/0.1 \text{ s}) \times (40 + 60) + (1 \text{ s}/0.2 \text{ s}) \times 10 = 1450 \text{ channels/s}$

File size: File size = header size + data size

Header size = $(904 + (\text{no. of recording channels} \times 232))$ bytes

Data size (for measurement channels) = $(\text{no. of recording measurement channels} \times 4 \times \text{no. of samples})$ bytes

Data size (for MATH channels) = $(\text{no. of recording measurement channels} \times 6 \times \text{no. of samples})$ bytes

No. of samples = Data length/Recording interval

Allowable size of data: Approximately 10 Mbyte

Approximate storage capacity in terms of time by CF card size:

Number of recorded channels	Recording Interval	128 MB	512 MB	1 GB
10 channels	10 ms	Approx. 8.8 hours	Approx. 1.4 days	Approx. 2.8 days
	100 ms	Approx. 3.7 days	Approx. 14.8 days	Approx. 28.9 days
	500 ms	Approx. 18.5 days	Approx. 74.0 days	Approx. 144 days
	1 s	Approx. 37.0 days	Approx. 148 days	Approx. 289 days
	2 s	Approx. 74.0 days	Approx. 296 days	Approx. 578 days (Approx. 1.5 years)
	5 s	Approx. 185 days	Approx. 740 days	Approx. 1446 days (Approx. 3.9 years)
20 channels	50 ms	Approx. 22.2 hours	Approx. 3.7 days	Approx. 7.2 days
	100 ms	Approx. 1.8 days	Approx. 7.4 days	Approx. 14.4 days
	500 ms	Approx. 9.2 days	Approx. 37.0 days	Approx. 72.3 days
	1 s	Approx. 18.5 days	Approx. 74.0 days	Approx. 144 days
	2 s	Approx. 37.0 days	Approx. 148 days	Approx. 289 days
	5 s	Approx. 92.5 days	Approx. 370 days (Approx. 1 year)	Approx. 723 days (Approx. 1.9 years)
30 channels	100 ms	Approx. 1.2 days	Approx. 4.9 days	Approx. 9.6 days
	500 ms	Approx. 6.1 days	Approx. 24.6 days	Approx. 48.2 days
	1 s	Approx. 12.3 days	Approx. 49.3 days	Approx. 96.4 days
	2 s	Approx. 24.6 days	Approx. 98.7 days	Approx. 192 days
	5 s	Approx. 61.7 days	Approx. 246 days	Approx. 482 days (Approx. 1.3 years)
60 channels	100 ms	Approx. 14.8 hours	Approx. 2.4 days	Approx. 4.8 days
	500 ms	Approx. 3.0 days	Approx. 12.3 days	Approx. 24.1 days
	1 s	Approx. 6.1 days	Approx. 24.6 days	Approx. 48.2 days
	2 s	Approx. 12.3 days	Approx. 49.3 days	Approx. 96.4 days
	5 s	Approx. 30.8 days	Approx. 123 days	Approx. 241 days

T03.EPS

Writing message: During execution of the recording action, a message synchronized with the recorded data can be included in the file. Five messages of up to 15 characters each are available for including in a single file, up to ten messages per file.

Operation upon failure recovery: If a power failure occurs during recording, the data up to the failure is appended upon recovery from the failure. The data after recovery is saved continuously to newly created files.

Operation when synchronizing time: If time synchronization to SNTP is carried out during recording, the time is saved to the data acquisition log file.

Thinned Value Recording Function

Overview: Apart from the measured and computed values file, a set of thinned values from the measured and computed values are saved to CF card.

Record start/stop: Executed simultaneously upon recording of the measured values and computed values. No trigger functions are available.

Recording operation: User can select Record or Do not record for thinned values.

Write mode: Select a record stop action of Single, Full stop, or Rotate.

Thinning time: Data recording is set for 1 per thinning time.

Set a thinning time of: 4, 5, 10, 20, or 30 sec; 1, 2, 3, 4, 5, 10, 20, or 30 min.; or 1 hour.

However, the thinning time cannot be set shorter than the measurement interval.

File name: Generated automatically in sequence using the date and time (cannot be specified by the user).

Data length: Select 30 minutes; 1, 2, 3, 4, 6, 8, or 12 hours; or 1, 2, 3, 5, 7, 10, 14 or 31 days.

However, it cannot be set so that the file size could exceed 10 Mbyte.

Also, the data length cannot be set shorter than the thinning time.

Recording channels: Can be specified for each channel (settings for recording of measured and computed values are set separately)

File size: The file size equation is the same as that for the computed value file.

Writing message: During execution of the recording action, a message synchronized with the recorded data can be included in the file. Five messages of up to 15 characters each are available for writing to a single file, up to ten messages per file.

Operation upon failure recovery: If a power failure occurs during recording, the data up to the failure is appended upon recovery from the failure. The data after recovery is saved continuously to newly created files.

Internal Backup Memory Specifications

Overview: Uses the main unit's internal backup memory (SRAM) to save data to CF card without loss before a power failure.

Backup memory capacity: For measured and computed value: 1.25 Mbyte
For thinned value: 256 Kbyte

Saving Settings

Overview: Saves settings to CF card. You can select setting values to save of channel settings, recording settings, communication settings, or other.

Save operation: Executed per user function keys on the main unit (used for the Event/Action function) or communication input (communication commands or browser). However, the main unit function keys cannot be used to enter file names (saved to a fixed file name of SETTING.PNL). File names can be specified using communication input or from a browser (the extension is fixed to PNL).

Load operation: Executed per user function keys on the main unit (used for the Event/Action function) or communication input (communication commands or browser). The main unit function keys cannot be used to enter file names (only the fixed file name of SETTING.PNL can be loaded). Files can be selected using communication input or from a browser.

Saving the Data Acquisition Log

Overview: Saves the data acquisition log (text file) to the CF card.

Save operation: When recording is stopped, all data acquisition logs saved on the main unit are saved. Another save operation is also carried out when recording is stopped. Up to 1021 data acquisition logs can be saved. If that number is exceeded, old logs are overwritten with new ones.

Saved information: Power ON/OFF, CF card insert/eject, formatting, recording operations, time synchronization, log saving, and other information.

File locations: Created in the DataN folder during recording.
Created in the root when recording is stopped.

File name: Fixed (RECORDLG.TXT)
The old log file in the CF card is overwritten.

Saving Alarm Summary

Overview: Saves alarm summary (text file) to the CF card.

Save operation: When recording is stopped, all alarm logs saved on the main unit are saved. Another save operation is also carried out when recording is stopped. Up to 256 alarm logs can be saved. If that number is exceeded, old logs are overwritten with new ones.

Saved information: Time alarm activation/release, channels, levels, types, and other items.

File locations: Created in the DataN folder during recording.
Created in the root when recording is stopped.

File name: Fixed (ALARMLG.TXT)
The old summary file in the CF card is overwritten.

Event/Action Function

Overview: By linking the Event function and Action function, you can control the operations of the main unit.

Number of possible settings: 30

Event operations: Select Edge or Level action.

Edge: The action is executed when the event is detected.

Level: The action is executed when the event is detected, and continues as long as the event continues.
The action stops when the event is cleared.

Events: Digital input information, alarm occurrence, relay output, internal timer time up, match time, user function key, and others.

Actions: Recording start/stop, activate trigger, MATH start/stop/reset/clear, reset timer, alarm ACK, flag input, write message, and others.

Internal Timer

Number of timers: 6

Types of timers: Relative timer, Absolute timer

Relative timer: Repeats time up every specified time interval. Time interval can be set in units of minutes.

Absolute timer: Using the specified reference time as a standard, repeats the time up every specified time interval. The reference time is set in units of minutes. The time up time is set using a time interval (parameter) of 1, 2, 3, 4, 5, 6, 10, 12, 15, 20, 30 min or 1, 2, 3, 4, 6, 8, 12, 24 h according to the following equation.

Time up time = reference time \pm time interval (parameter) \times n (where n = 0, 1, 2, ...)

Match Time

Number of match times: 3

Match time function: Time up occurs upon specified time.

Choose one of the following three time settings: Every month on the specified day or time (hr, min), every week on the specified day or time; or every day at the specified time.

The setting is in units of minutes.

Initialization of Settings

Initialization of all settings: Initializes all setting values and measured values on the main unit.

The following two ways can be used to execute the function.

1. Communication command
2. Dip switch operation and power ON

Initialization of all settings excluding communication parameters:

Initializes all setting values and measured values except for communication parameters (serial communication settings and Ethernet settings). Executed using communication commands.

Initialization of the CF Card

Overview: Formats the CF card. Executed using communication commands.

Format type: FAT16, logical format only

Supported CF card size: Up to 2 GB

Communication Specifications

Overview: Ethernet interface comes standard with the Main Module (MW100).

Also, either an RS-232 or RS-422A/485 interface can be added to the main module as an option.

Ethernet Interface Specifications

Interface: Ethernet (10 Base-T)

Main protocols: FTP, SMTP, SNTP, DHCP, DNS, HTTP, ModbusTCP, and a dedicated MW100 protocol.

Communication services: Send/receive setting values, send measured values and computed values, maintenance/diagnosis of the communication connection, and others.

Login function: Use when accessing a setting/measurement server, maintenance/diagnostic server, FTP server, or HTTP server.

Up to 10 users can be registered.

Time out function: Enables setting of TCP keep alive (30 sec.) and application time out (1-120 min.)

DHCP function: The IP address is automatically obtained from the DHCP server

SNTP function (This function is only enabled when the shortest measurement interval within the unit is two seconds or more.)

Client function: Gets time information from the specified SNTP server such as when the power is turned ON and when measurement starts.

Server function: Supplies time information to any MW100s connected to the network.

Mail function: Sends timing information via e-mail including the time of alarm activation/release, specified time, file creation time, time at which free memory space drops below specified amount, time power turned ON, and time operation errors occur.

Two mail destinations can be set.

Supports authentication mechanism with POP3 before SHTP.

FTP function

Client function: Files from the CF card containing measured values, computed values, and thinned values, as well as data acquisition logs and alarm summaries are automatically sent to the FTP server.

A primary and secondary destination server can be specified.

Server function: File transfers from the CF card, directory manipulation within the CF card, deletion of files from the CF card, and other functions can be carried out through requests from the computer.

HTTP function: Enables entry of settings on the MW100 and real time monitoring of measured and computed values using a Web browser, and file acquisition on the CF card using WebDAV, and other functions.

Supported OS and browser: Windows 2000/XP, Internet Explorer 5.0 or later

Number of possible connections using the dedicated MW100 protocol: 4 (sending and receiving of settings, receiving of measured/computed values, and other communication operations are available using the dedicated MW100 protocol.)

RS-232 Interface Specifications (/C2 Option)

Connection method: Point-to-point

Communication: Half-duplex

Synchronization: Start-stop synchronization

Baud rate: Select 1200, 2400, 4800, 9600, 19200, 38400, 57600, or 115200 bps

Start bit: 1 bit, fixed

Data length: Select either 7 or 8 bits

Parity: Select Odd, Even, or None

Stop bit: Select either 1 or 2 bits

Hardware handshaking: RS-CS can be used

Software handshaking: X-ON, X-OFF can be used

Receive buffer length: 2047 Byte

Protocol: Dedicated protocol and Modbus/RTU

Communication services: Send/receive setting values, send measured and computed values.

RS-422A/485 Interface (/C3 Option)

Connection method: Multidrop, 4-wire 1:32, 2-wire 1:31

Communication: Half-duplex

Synchronization: Start-stop synchronization

Baud rate: Select 1200, 2400, 4800, 9600, 19200, 38400, 57600, or 115200 bps

Start bit: 1 bit, fixed

Data length: Select either 7 or 8 bits

Parity: Select Odd, Even, or None

Stop bit: Select either 1 or 2 bits

Receive buffer length: 2047 Byte

Protocol: Dedicated protocol and Modbus/RTU

Communication services: Send/receive setting values, send measured and computed values.

Communication Input Function:

All settings on the main unit other than dip switch operation can be performed with communication commands.

Communication Output Function:

The following information about the main unit can be output using communication commands.

Item	Description
Measured value	Outputs most recent measured value
Computed value	Outputs most recent computed value
Output value	Outputs most recent output value
Units, decimal place	Outputs the units and decimal place for measured and computed values
Measured and computed value FIFO data	Outputs the measured and computed values from the FIFO buffer
Thinned values FIFO data	Outputs the thinned values from the FIFO buffer
Alarm summary	Outputs the alarm summary
Message summary	Outputs the message summary
Data acquisition log	Outputs the data acquisition log
Computation status	Outputs the MATH status
Recording status	Outputs the recording status
Operation log	Outputs the key operation log
Communication log	Outputs the communication log
FTP log	Outputs the FTP operation log
SMTP client log	Outputs the mail transmission log
DHCP log	Outputs the DHCP log
HTTP log	Outputs the HTTP log
Modbus client log	Outputs the Modbus client log
Modbus client command	Outputs the Modbus client status
Modbus client connection status	Outputs the Modbus client connection status
Modbus master log	Outputs the Modbus master log
Modbus master command	Outputs the Modbus client status
Modbus master connection status	Outputs the Modbus master connection status
Status	Status byte information
User information	User settings
Relay information	Relay action information
System information	Outputs the module recognition status
Analog output information	Outputs the analog output value information
Initial balancing information	Outputs initial balance information for the strain input module

T03-2.EPS

Common to Modbus Master Function and Modbus Slave Function

Communication possible with Modbus protocol

Communication media: RS-232, RS-422A/485

Control method: No flow control (None only)

Baud rate: Select 1200, 2400, 4800, 9600, 19200, 38400, 57600, or 115200 bps

Start bit: 1 bit, fixed

Data length: 8 bit, fixed

Parity: Select Odd, Even, or None

Stop bit: Select either 1 or 2 bits

Transmission mode: RTU (remote terminal unit) mode only

Modbus Master Function (/M1 option)

Communication interval: The interval for data loading from other instruments is selected from the following.

100, 200, 250, 500 ms, or 1, 2, 5, or 10 s

- Timeout time: From the following, select a timeout time for no response from the specified slave after sending commands from the main unit.
100, 200, 250, 500 ms, or 1 s
- Number of retries: The number of transmissions attempted if no response to commands from the main unit are received from the slaves. Select from the following: OFF, 1, 2, 3, 4, or 5
- Communication recovery time: You can select from the following the send interval for the command sent after the point at which there is no response from the slaves after sending commands the specified number of retry times.
0 to 120 s
- Wait between commands: Select a time to wait between receiving of the response to a command until the next command is sent.
OFF, 10, 20, 50, 100 ms
- Supported function: The functions that the MW100 supports are as follows.

Function Code	Function	Operation
3	Read hold registers (4XXXX, 4XXXXX)	MW100 loads data from the hold registers of another instrument to its communication input channel data.
4	Read input registers (3XXXX, 3XXXXX)	MW100 writes data from the input register of another instrument to its communication input channel data.
6	Simple write to hold registers (4XXXX, 4XXXXX)	MW100 writes to the hold register of another instrument.
16	Write to hold registers (4XXXX, 4XXXXX)	MW100 writes to the hold register of another instrument.

T03-3.EPS

- Command settings: Up to 100 commands can be set.
- Command items: Loading channels: C001 to C300
Writing channels: 001 to 060, A001 to A300, C001 to C300
Address: 1 to 247
Input registers: 30001 to 39999, 300001 to 365535
Hold registers: 40001 to 49999, 400001 to 465535
Type:

Type	Description
INT16	Signed 16-bit integer
UINT16	Unsigned 16-bit integer
INT32_B	Signed 32-bit integer (from upper to lower.)
INT32_L	Signed 32-bit integer (from lower to upper.)
UINT32_B	Unsigned 32-bit integer (from upper to lower.)
UINT32_L	Unsigned 32-bit integer (from lower to upper)
FLOAT_B	32-bit floating decimal (from upper to lower.)
FLOAT_L	32-bit floating decimal (from lower to upper)

T03-4.EPS

Modbus Slave Function

- Slave address: 1 to 247
- Supported function: The functions that the MW100 supports are as follows.

Function Code	Function	Operation
3	Read hold registers (4XXXX)	MW100 read communication input data 16 written by function code 6 or 16
4	Read input registers (3XXXX)	MW100 reads the main instrument's measured, computed, and time data.
6	Simple write to hold registers (4XXXX)	MW100 writes to the main instrument's registers communication input data.
8	Loop back test	MW100 performs the loop back test on the main instrument. Main instrument only support message return (diagnostic code (0x00)).
16	Write to hold registers (4XXXX)	MW100 writes to the main instrument's communication input data.

T03-5.EPS

Register Assign (Modbus Server Functions and Sharing)

Input Registers	Data	Data Type								
30001 30002 30119 30120	Lower byte of measured data of measurement channel 001 Upper byte of measured data of measurement channel 001 Lower byte of measured data from measurement channel 060 Upper byte of measured data from measurement channel 060 • No decimal place information.	Int 32								
31001 31002 31119 31120	Lower byte of measured data from measurement channel 001 Upper byte of measured data from measurement channel 001 Lower byte of measured data from measurement channel 060 Upper byte of measured data from measurement channel 060 • Includes decimal place information.	Float								
32001 32060	Alarm status of measured data of measurement channel 001 Alarm status of measured data of measurement channel 060 • Register structure and alarm status values Alarm <table border="1" style="margin-left: 40px;"> <tr> <td style="text-align: center;">2</td> <td style="text-align: center;">1</td> <td style="text-align: center;">4</td> <td style="text-align: center;">3</td> </tr> <tr> <td style="text-align: center;">4 bits</td> <td style="text-align: center;">4 bits</td> <td style="text-align: center;">4 bits</td> <td style="text-align: center;">4 bits</td> </tr> </table> 0: No alarms 1: Upper limit alarm occurs 2: Lower limit alarm occurs 3: Differential upper limit alarm occurs 4: Differential lower limit alarm occurs 5: Rate of change upper limit alarm occurs 6: Rate of change lower limit alarm occurs	2	1	4	3	4 bits	4 bits	4 bits	4 bits	Bit string
2	1	4	3							
4 bits	4 bits	4 bits	4 bits							
33001 33002 33599 33600	Lower byte of computed data of computation channel A001 Upper byte of computed data of computation channel A001 Lower byte of computed data of computation channel A300 Upper byte of computed data of computation channel A300 • No decimal place information.	Bit string								
34001 34002 34599 34600	Lower byte of computed data of computation channel A001 Upper byte of computed data of computation channel A001 Lower byte of computed data of computation channel A300 Upper byte of computed data of computation channel A300 • Includes decimal place information.	Int 32								
35001 35300	Alarm status of computed data of computation channel A001 Alarm status of computed data of computation channel A300 • Register structure and alarm status value: Same as alarm status of measured data.	Float								
39001 39002 39003 39004 39005 39006 39007 39008	Year Month Day Hours Minute Second Milliseconds DST(0, 1)	Int 16								

T03-6.EPS

Hold Registers	Data	Data Type
40001	Lower byte of communication input channel C001	Float
40002	Upper byte of communication input channel C001	
40599	Lower byte of communication input channel C300	
40600	Upper byte of communication input channel C300	

T03-7.EPS

Modbus error response: The main unit returns the following error codes to the master instrument.

Code	Function	Operation
1	Function code invalid	Requested non-supported function
2	Invalid register number	Attempted to read/write registers for which no corresponding channels could be found.
3	Invalid number of registers	The specified number of registers was zero.
7	Could not be executed	Attempted to read MATH registers from an instrument without the MATH function option.

T03-8.EPS

However, there is no response in the following cases.

- CRC Error
- Errors other than in above table.

Modbus Client Function (/M1 option)

Communication possible with Modbus/TCP protocol

Communication media: Ethernet 10 Base-T

Communication interval: You can select the following:

100, 200, 250, or 500 ms, or 1, 2, 5, or 10 s

Depending on the load on the main unit, data reading and writing may not be able to be performed at the set communication interval resulting in data loss. If this occurs, the communication input channel holds the previous value. In this case, you must lengthen the communication interval, or reduce the load on the main unit (such as by lengthening the measurement interval or reducing the number of channels or Modbus commands).

Connection wait time: The connection can be dropped if there is no response from the server after sending commands.

You can select the connection wait time from the following.

Forever (do not drop connection), 0 to 10 s

Communication recovery wait: The time after which commands are sent following disconnection after the connection wait time. Selected from the following: Soon (communication interval), 1-60 s

Connection destination (server): Up to 10 can be set.

Supported function: Same as Modbus master function

Command settings: Up to 100 commands can be set.

Command items: Loading channels: C001 to C300

Writing channels: 001 to 060, A001 to A300, C001 to C300

Server (specified by registered number): 1 to 10

Input registers: Same as Modbus master function

Hold registers: Same as Modbus master function

Type: Same as Modbus master function

Modbus Server Function

Communication possible with Modbus/TCP protocol

Communication media: Ethernet 10 Base-T

Port: 502/tcp

Communication interval: 100, 200, 250, or 500 ms, or 1, 2, 5, or 10 s

Maximum no. of simultaneous connections: 4

Receive timeout: Drops communication connection if packets not received for 30 s (fixed) or more

Supported function: Same as Modbus slave function. However, there is no function code 8.

Register assignments: Same as Modbus slave function

Modbus error response: Same as Modbus slave function

Communication Log Information

- Overview: The following communication related log information can be saved in the memory of the main unit.
Communication log, FTP client operation log, e-mail operation log, DHCP operation log, SNTP client operation log
- Referencing method: Output only through communication. Logs are initialized when the power is disconnected, and are not backed up.
- Maximum number of saved logs: 200 communication logs, and 50 other logs. If that number is exceeded, old logs are overwritten with new ones.

Other Specifications

- Tags: Tag strings of up to 15 characters can be set for measurement channels and MATH channels.
Select channel or tag display for all channels together.
- Date & time: Time settings consist of date, time, and time zone. These settings are backed up in event of a power failure.
- Internal clock accuracy: ± 100 ppm
- Summer/winter time: The time on the internal clock is updated on the specified month, week, day of the week, and time.
- Summer: The time on the internal clock is moved one hour ahead of the month, week, day of the week, and hour set as Summer time.
- Winter: The time on the internal clock is moved one hour back from the month, week, day of the week, and hour set as Winter time.
- Power consumption: Approximately 8 W for the main module alone.
- Common-mode voltage: 150 VACrms (50/60 Hz) between DC power supply terminal and earth terminal.
- Insulation resistance: 20 M Ω or more (500 VDC) between power supply terminal and earth terminal
- Withstand voltage: AC power: 1500 VACrms (50/60 Hz) between power supply terminal and earth terminal for 1 minute.
DC power: 1000 VACrms (50/60 Hz) between power supply terminal and earth terminal for 1 minute.
- External dimensions: Approximately 105 (W) \times 131 (H) \times 137 (D) mm (MW100 main module alone)
- Weight: Approximately 1 kg (MW100 main module alone)

- **Base Plate (MX150)**

Number of main modules that can be equipped: 1 (always equipped)

Number of I/O modules that can be equipped: 1-6 (specified according to the suffix codes)

- **AC Adapter (Accessory for the MW100-E-2x / Model 772075)**

Rated power supply voltage: AC power supply: 100-240 VAC

Range of operating power supply voltage: AC power supply: 90-250 VAC

Rated power supply frequency: 50-60 Hz

Rated output voltage: 12.0 V

Operating temperature range: 0-40°C

Operating humidity: 20-80% RH (no condensation)

Storage temperature: -20-70°C

Storage humidity: 10-90% RH (no condensation)

Insulation resistance: 50 MΩ or more (500 VDC) between AC power supply input and DC output.

Withstand voltage: 3000 VAC (50/60 Hz) between AC power supply input and DC output for 1 minute.

Lifespan: Approximately 8400 hours (at ambient temperature of 25°C, under maximum load)

External dimensions: Approximately 114.5 × 49.5 × 27 mm

Weight: 270 g or less

• **Four-Channel High-Speed Universal Input Module (MX110-UNV-H04)**

Style number: S1

Types of measurement: DC voltage, thermocouple, 3-wire RTD, DI (non-voltage contact, level (5 V logic))

Number of measurement points: 4 (Each channel is equipped with an independent A/D converter. (for a total of four on a single module))

Input method: Floating unbalanced input, isolation between channels

A/D resolution: $\pm 20000/\pm 6000$ (16-bit A/D is used)

Measurement interval and A/D integral time: A/D integral time is determined by measurement intervals

Measurement interval	Integral time	Noise rejection/remarks
10 ms	1.67 ms ^(*1)	600 Hz and its integer multiples
50 ms	16.67 ms	60 Hz and its integer multiples
	20 ms	50 Hz and its integer multiples
	Auto ^(*2)	Power supply frequency is automatically detected and is set to 16.67/20 ms automatically.
100 ms	36.67 ms	50/60 Hz, and the respective integer multiples
200 ms		
500 ms	100 ms	10 Hz and its integer multiples
1 s	200 ms	Fc = 5 Hz low pass filter
2, 5, 10, 20, 30, 60 s		

T04.EPS

(*1) If thermocouple measurements are taken at an integral time of 1.67 ms, the measured values may be susceptible to inaccuracies due to power supply frequency noise. If this is the case, set the integral time to 16.67 ms or longer (for a power supply frequency of 60 Hz), or 20 ms or longer (for a power supply frequency of 50 Hz). On this module, the power supply frequency noise can be rejected by selecting a measurement interval of 50ms or more. (on DAQMASTER, the integral time is automatically set when selecting the measurement interval.)

(*2) Set to 20 ms when using DC power.

Measurement Ranges and Accuracies

The accuracy applies to standard operating conditions: ambient temp: 23 ±2°C, ambient humidity: 55 ±10% RH, supply voltage: 90 to 250 VAC, power frequency: 50/60 Hz ±1%, warm-up time: at least 30 minutes, without adverse conditions such as vibrations.

Input	Type	Rated measurement range	Measurement accuracy integral time 16.67 ms or more	Measurement accuracy integral time 1.67 ms	Maximum resolution (1 digit)		
DC voltage	20 mV	-20.000 to 20.000 mV	±(0.05% of rdg. + 5 digits)	±(0.1% of rdg. + 25 digits)	1 μV		
	60 mV	-60.00 to 60.00 mV	±(0.05% of rdg. + 2 digits)	±(0.1% of rdg. + 10 digits)	10 μV		
	200 mV	-200.00 to 200.00 mV			10 μV		
	2 V	-2.0000 to 2.0000 V	±(0.05% of rdg. + 5 digits)		100 μV		
	6 V	-6.000 to 6.000 V	±(0.05% of rdg. + 2 digits)		1 mV		
	20 V	-20.000 to 20.000 V			1 mV		
	100 V	-100.00 to 100.00 V			10 mV		
10 mV							
Thermocouple (excludes RJC accuracy, when burnout is OFF)	R *1	0.0 to 1760.0°C	±(0.05% of rdg. + 1°C) However, R, S: 0 to 100°C: ±3.7°C 100 to 300°C: ±1.5°C	±(0.1% of rdg. + 4°C) However, R, S: 0 to 100°C: ±10°C 100 to 300°C: ±5°C	0.1°C		
	S *1					0.0 to 1820.0°C	400 to 600°C: ±2°C Less than 400°C: accuracy not guaranteed
	B *1	-200.0 to 1370.0°C	±(0.05% of rdg. + 0.7°C) However, -200 to -100°C: ±(0.05% of rdg. + 1°C)	±(0.1% of rdg. + 3.5°C) However, -200 to -100°C: ±(0.1% of rdg. + 6°C)			
	K *1					-200.0 to 800.0°C	±(0.05% of rdg. + 0.5°C) However, J, L: -200 to -100°C: ±(0.05% of rdg. + 0.7°C)
	E *1	0.0 to 1300.0°C	±(0.05% of rdg. + 0.7°C)	±(0.1% of rdg. + 3.5°C)			
	J *1					0.0 to 2315.0°C	±(0.05% of rdg. + 1°C)
	T *1	0.0 to 300.0 K	±(0.05% of rdg. + 0.7 K)	±(0.1% of rdg. + 3.5 K)			
	L *2					0.0 to 2315.0°C	±(0.05% of rdg. + 1°C)
	U	0.0 to 300.0 K	±(0.05% of rdg. + 0.7 K)	±(0.1% of rdg. + 3.5 K)			
	N *3					0.0 to 300.0 K	±(0.05% of rdg. + 0.7 K)
	W *4	0.0 to 300.0 K	±(0.05% of rdg. + 0.7 K)	±(0.1% of rdg. + 3.5 K)			
	KPvsAu7Fe					0.0 to 300.0 K	±(0.05% of rdg. + 0.7 K)
3-wire RTD (Measurement current 1 mA)	Pt100 *5	-200.0 to 600.0°C	±(0.05% of rdg. + 0.3°C)	±(0.1% of rdg. + 1.5°C)	0.1°C		
	JPt100 *5	-200.0 to 550.0°C					
	Pt100 (high resolution)	-140.00 to 150.00°C			0.01°C		
	JPt100 (high resolution)	-140.00 to 150.00°C					
	Ni100 SAMA *6	200.0 to 250.0°C			0.1°C		
	Ni100 DIN *6	-60.0 to 180.0°C					
3-wire RTD (Measurement current 2 mA)	Ni120 *7	-70.0 to 200.0°C	±(0.05% of rdg. + 0.3°C)	±(0.1% of rdg. + 1.5°C)	0.1°C		
	Pt100 *5	-200.0 to 250.0°C					
	JPt100 *5	-200.0 to 250.0°C					
	Pt100 (high resolution)	-140.00 to 150.00°C			0.01°C		
	JPt100 (high resolution)	-140.00 to 150.00°C					
	Pt50 *5	-200.0 to 550.0°C			±(0.1% of rdg. + 0.7°C)	±(0.2% of rdg. + 2.5°C)	0.1°C
	Cu10 GE *8	-200.0 to 300.0°C					
	Cu10 L&N *8	-200.0 to 300.0°C					
Cu10 WEED *8	-200.0 to 300.0°C						
Cu10 BAILEY *8	-200.0 to 300.0°C	±(0.05% of rdg. + 0.3 K)	±(0.1% of rdg. + 1.5K)	0.1 K			
J263B	0.0 to 300.0 K						
DI	Level	Vth = 2.4 V	Threshold level accuracy ±0.1 V				
	Non-voltage contact	100 Ω or less: ON, 10 kΩ or more: OFF *9					

*1 R, S, B, K, E, J, T: ANSI, IEC 584, DIN IEC 584, JIS C 1602-1981

*2 L: Fe-CuNi, DIN43710/U: Cu-CuNi, DIN 43710

*3 N: Nicrosil-Nisil, IEC 584, DIN IEC 584

*4 W: W-5%RE-W-26%Re (Hoskins Mfg Co)

*5 Pt50: JIS C 1604-1981, JIS C 1606-1986/Pt100: JIS C 1604-1989, JIS C 1606-1989, IEC 751, DIN IEC 751/JPt100: JIS C 1604-1981, JIS C 1606-1989

*6 SAMA/DIN

*7 McGRAW EDISON COMPANY

*8 Guaranteed accuracy range Cu10 GE: -84.4 to 170.0°C/Cu10 L&N: -75.0 to 150.0°C/Cu10 WEED: -20.0 to 250.0°C/Cu10 BAILEY: -20.0 to 250.0°C

*9 To be determined at the measurement current of 1 mA and within the range of 2 V. The threshold level is approximately 0.8 V.

T05.EPS

Measurement Ranges and Accuracies (continued)

Input	Type	Rated measurement range	Measurement accuracy integral time 16.67 ms or more	Measurement accuracy integral time 1.67 ms	Maximum resolution (1 digit)
DC voltage	60 mV (high resolution)	0.000 to 60.000 mV	±(0.05% of rdg.+ 20 digits)	±(0.1% of rdg.+100 digits)	1 μV
	1 V	-1.0000 to 1.0000 V	±(0.05% of rdg.+ 2 digits)	±(0.1% of rdg.+10 digits)	100 μV
	6 V (high resolution)	0.0000 to 6.0000 V	±(0.05% of rdg.+ 20 digits)	±(0.1% of rdg.+100 digits)	100 μV
Thermocouple (excludes RJC accuracy, when burnout is OFF)	PLATINEL	0.0 to 1400.0°C	±(0.05% of rdg.+ 1°C)	±(0.1% of rdg.+ 4°C)	0.1°C
	PR40-20 *1	0.0 to 1900.0°C	±(0.05% of rdg.+ 2.5°C) However, 300 to 700°C: ±6°C Less than 300°C: accuracy not guaranteed	±(0.1% of rdg.+ 12°C) However, 300 to 700°C: ±25°C Less than 300°C: accuracy not guaranteed	
	NiNiMo	0.0 to 1310.0°C	±(0.05% of rdg.+ 0.7°C)	±(0.1% of rdg.+ 2.7°C)	
	WRe3-25	0.0 to 2400.0°C	±(0.05% of rdg.+ 2°C) However, 0 to 200°C: ±2.5°C 2000°C or more: ±(0.05% of rdg.+ 4°C)	±(0.1% of rdg.+ 7°C) However, 0 to 200°C: ±12°C 2000°C or more: ±(0.1% of rdg.+ 11°C)	
	W/WRe26	0.0 to 2400.0°C	±(0.05% of rdg.+ 2°C) However, 100 to 300°C: ± 4°C Less than 100°C: accuracy not guaranteed	±(0.1% of rdg.+ 8.5°C) However, 100 to 300°C: ±12°C Less than 100°C: accuracy not guaranteed	
	Type-N (AWG14)	0.0 to 1300.0°C	±(0.05% of rdg.+ 0.7°C)	±(0.1% of rdg.+ 3.5°C)	
	TXK GOST	-200.0 to 600.0°C	±(0.05% of rdg.+ 0.5°C) However, -200 to 0°C: ±(0.2% of rdg.+ 0.7°C)	±(0.1% of rdg.+ 2.5°C) However, -200 to 0°C: ±(1% of rdg.+ 2.5°C)	
3-wire RTD (Measurement current 1 mA)	Pt100 (high noise resistance)	-200.0 to 600.0°C	±(0.05% of rdg.+ 0.3°C)	±(0.1% of rdg.+ 2.5°C)	0.1°C
	JPt100 (high noise resistance)	-200.0 to 550.0°C			
	Pt100 GOST	-200.0 to 600.0°C			
3-wire RTD (Measurement current 2 mA)	Cu10 at 20°C alpha=0.00392	-200.0 to 300.0°C	±(0.1% of rdg.+ 0.7°C)	±(0.2% of rdg.+ 2.5°C)	0.1°C
	Cu10 at 20°C alpha=0.00393	-200.0 to 300.0°C			
	Cu25 at 0°C alpha=0.00425	-200.0 to 300.0°C	±(0.1% of rdg.+ 0.5°C)	±(0.2% of rdg.+ 2°C)	0.1°C
	Cu53 at 0°C alpha=0.00426035	-50.0 to 150.0°C	±(0.05% of rdg.+ 0.3°C)	±(0.1% of rdg.+ 1.5°C)	0.1°C
	Cu100 at 0°C alpha=0.00425	-50.0 to 150.0°C			
	Pt25(JPt100×1/4)	-200.0 to 550.0°C	±(0.1% of rdg.+ 0.5°C)	±(0.2% of rdg.+ 2°C)	0.1°C
	Cu10 GE *2 (high resolution)	-200.0 to 300.0°C	±(0.1% of rdg.+ 0.7°C)	±(0.2% of rdg.+ 2.5°C)	0.1°C
	Cu10 L&N *2 (high resolution)	-200.0 to 300.0°C			
	Cu10 WEED *2 (high resolution)	-200.0 to 300.0°C			
	Cu10 BAILEY *2 (high resolution)	-200.0 to 300.0°C			
	Pt100 (high noise resistance)	-200.0 to 250.0°C	±(0.05% of rdg.+ 0.3°C)	±(0.1% of rdg.+ 1.5°C)	0.1°C
	JPt100 (high noise resistance)	-200.0 to 250.0°C			
	Cu100 GOST	-200.0 to 200.0°C	±(0.05% of rdg.+ 0.3°C)	±(0.1% of rdg.+ 1.5°C)	0.1°C
	Cu50 GOST	-200.0 to 200.0°C	±(0.05% of rdg.+ 0.3°C)	±(0.1% of rdg.+ 1.5°C)	0.1°C
	Cu10 GOST	-200.0 to 200.0°C	±(0.1% of rdg.+ 0.7°C)	±(0.2% of rdg.+ 2.5°C)	0.1°C

*1 PR40-20: PtRh20%-PtRh40% (John Matthey Plc)

*2 Guaranteed accuracy range Cu10 GE: -84.4 to 170.0°C/Cu10 L&N: -75.0 to 150.0°C/Cu10 WEED: -20.0 to 250.0°C/Cu10 BAILEY: -20.0 to 250.0°C

- Reference junction compensation:
External/internal switchover can be performed for each channel.
The Remote RJC function is available.
- Reference junction compensation accuracy:
During the measurement of 0°C or more and during the input terminal temperature balance
Type R, S, W: $\pm 1^\circ\text{C}$
Type K, J, E, T, N, L, U, TXK GOST: $\pm 0.5^\circ\text{C}$
Type N (AWG14), PLATINEL, NiNiMo, WRe3-25, W/WRe26: $\pm 1^\circ\text{C}$
Internal reference junction compensation for Type B and PR40-20 is fixed to 0°C.
- Maximum input voltage:
1 VDC range or less, thermocouple, RTD, DI (contact only): ± 10 VDC (continuous)
Other measurement ranges: ± 120 VDC (continuous)
- Normal mode voltage:
DCV, TC, DI (level): 1.2 times of rated range or less (50/60 Hz, peak values including signals)
RTD 100 Ω system: 50 mV peak
RTD 10, 25, 50 Ω systems: 10 mV peak
- Normal mode rejection ratio (NMRR):
40 dB or more when the integral time is 16.67 ms or more (50/60 Hz $\pm 0.1\%$)
50/60 Hz is not rejected when the integral time is 1.67 ms.
- Common mode voltage:
600 VACrms (50/60 Hz), reinforced (double) insulation
- Common mode rejection ratio (CMRR):
120 dB or more when the integral time is 16.67 ms or more
80 dB or more when the integral time is 1.67 ms
(50/60 Hz $\pm 0.1\%$, 500 Ω imbalance, between the minus measurement terminal and ground)
- Common mode between channels:
250 VACrms (50/60 Hz), reinforced (double) insulation
- Noise rejection: Rejection by the integrating A/D and the use of low pass filters
- Input resistance: 10 M Ω or more for the DC voltage of 1 V range or less and also for the thermocouple range
Approximately 1 M Ω if the DC voltage is 2 V range or more
Approximately 1 M Ω while the measurement operation is stopped
- Insulation resistance:
20 M Ω or more between the input and ground (500 VDC)
- Input bias current: 10 nA or less (except for the burn-out setting)
- Withstand voltage:
2300 VACrms (50/60 Hz) between input terminals, one minute
3700 VACrms (50/60 Hz) between an input terminal and ground, one minute
- Input signal source resistance:
2 k Ω or less for DC voltage and thermocouple
10 Ω or less per cable for RTD 50 Ω or 100 Ω systems
1 Ω or less per cable for RTD 10 Ω or 25 Ω systems
- Thermocouple burn-out:
Superposed electric current system, detection within the thermocouple range ("ON/OFF" possible), the up/down setting possible, detection current at approximately 100 nA, 2 k Ω or less being normal, and 10 M Ω or more being disconnected.
Influence on measurement accuracy: ± 15 μV or less (influence on signal source resistance is not included)
- Parallel capacity during RTD: 0.01 μF or less
- Power consumption: Approximately 3 W
- External dimension: Approximately 57 \times 131 \times 151 mm (including the terminal cover)
- Weight: Approximately 0.5 kg
- Terminal type: Clamp terminal. Attachable/detachable per channel.
- Applicable cable size: 0.2-2.5 mm² (AWG24-12)

Influence of operating conditions (applicable if the integral time is 16.67 ms or more)

Warm-up time: 30 minutes or more after the power supply is turned on.

Influence of ambient temperature:

Influence on a change in ambient temperature of 10°C is within $\pm(0.05\%$ of rdg. + 0.05% of range). However, during Cu10 Ω : $\pm(0.2\%$ of range + 1 digit)

Influence of power supply fluctuations:

Specifications of accuracy are satisfied at AC power 90-132 V or 180-250 V

Influence of external magnetic fields:

Fluctuations on external magnetic fields of alternate current (50/60 Hz) 400 A/m are $\pm(0.1\%$ of rdg. + 10 digits) or less.

Influence of signal source resistance:

Influences on fluctuations of signal source resistance (1 k Ω) of voltage and thermocouple are:

Voltage: 1 V range or less

$\pm 10 \mu\text{V}$ or less

2 V range or more

$\pm 0.15\%$ of rdg. or less

Thermocouple: $\pm 10 \mu\text{V}$ or less. However, $\pm 150 \mu\text{V}$ or less when the burn-out is set

RTD: Fluctuation (one common resistance value for three cables) on a change of 10 Ω per cable for 100 Ω systems is $\pm 0.1^\circ\text{C}$ or less ($\pm 1.0^\circ\text{C}$ or less for other systems).

Fluctuation on the difference of 40 m Ω in resistance values among conductors (maximum difference among three cables) shall be approximately 0.1°C (for Pt100)

Influence of attitude:

Basically, the system shall be used in a horizontal position with its legs extended downward.

Influence of vibrations:

Fluctuations when sine wave vibrations in the frequency of 10-60 Hz and at an acceleration of 0.2 m/s² are applied for two hours respectively in three axis directions shall be $\pm(0.1\%$ of rdg. + 1 digit) or less.

• Ten-Channel Medium-Speed Universal Input Module (MX110-UNV-M10)

Style number: S1

Types of measurement: DC voltage, thermocouple, 3-wire RTD, DI (non-voltage contact, level (± 5 V logic))

Number of measurement points: 10 (scanning of 10 channels with one A/D)

Input method: Floating unbalanced input, isolation between channels (Note that RTD is common among “b” terminals.)

A/D resolution: $\pm 20000/\pm 6000$ (16-bit A/D is used)

Measurement interval and A/D integral time: A/D integral time is determined by measurement intervals.

Measurement interval	Integral time	B.O. detection cycle	Noise rejection /remarks
100 ms	1.67 ms ^(*2)	1 s ^(*1)	600 Hz and its integer multiples
200 ms			
500 ms	16.67 ms	Measurement interval	60 Hz and its integer multiples
	20 ms		50 Hz and its integer multiples
	Auto ^(*3)		Power supply frequency is automatically detected and is set to 16.67/20 ms
1 s	36.67 ms		50/60 Hz and the respective integer multiples
2 s	100 ms ^(*4)		10 Hz and its integer multiples ^(*4)
5 s	200 ms ^(*5)		Fc = 5 Hz low pass filter ^(*5)
10, 20, 30, 60 s	200 ms		Fc = 5 Hz low pass filter

T07.EPS

- (*1) This is because the burn-out cannot be detected until up to 10 measurements have occurred (about one second) if measurement is started in the burn-out state. (If a measurement interval is 100 ms, the burn-out detection executed in one measurement interval is for one channel only.)
- (*2) If thermocouple measurements are taken at an integral time of 1.67 ms, the measured values may be susceptible to inaccuracies due to power supply frequency noise. If this is the case, set the integral time to 16.67 ms or longer (for a power supply frequency of 60 Hz), or 20 ms or longer (for a power supply frequency of 50 Hz). On this module, the power supply frequency noise can be rejected by selecting a measurement interval of 500ms or more. (on DAQMASTER, the integral time is automatically set when selecting the measurement interval.)
- (*3) Set to 20 ms when using DC power.
- (*4) When using the SNTP time synchronization function, the integral time is 36.67 ms. Also, in this case, noise of 50 Hz, 60 Hz, and their integer multiples are rejected.
- (*5) When using the SNTP time synchronization function, the integral time is 100 ms. Also, in this case, noise of 10 Hz and its integer multiples are rejected.

Measurement Ranges and Accuracies

The accuracy applies to standard operating conditions: ambient temp: 23 ±2°C, ambient humidity: 55 ±10% RH, supply voltage: 90 to 250 VAC, power frequency: 50/60 Hz ± 1%, warm-up time: at least 30 minutes, without adverse conditions such as vibrations.

Input	Type	Rated measurement range	Measurement accuracy integral time 16.67 ms or more	Measurement accuracy integral time 1.67 ms	Maximum resolution (1 digit)	
DC voltage	20 mV	-20.000 to 20.000 mV	±(0.05% of rdg. + 5 digits)	±(0.1% of rdg. + 25 digits)	1 μV	
	60 mV	-60.00 to 60.00 mV	±(0.05% of rdg. + 2 digits)		10 μV	
	200 mV	-200.00 to 200.00 mV			10 μV	
	2 V	-2.0000 to 2.0000 V	±(0.05% of rdg. + 5 digits)		±(0.1% of rdg. + 10 digits)	100 μV
	6 V	-6.000 to 6.000 V	±(0.05% of rdg. + 2 digits)			1 mV
	20 V	-20.000 to 20.000 V				1 mV
	100 V	-100.00 to 100.00 V				10 mV
Thermocouple RJC accuracy not included	R *1	0.0 to 1760.0°C	±(0.05% of rdg. + 1°C) However, R, S: 0 to 100°C: ±3.7°C 100 to 300°C: ±1.5°C	±(0.1% of rdg. + 4°C) However, R, S: 0 to 100°C: ±10°C 100 to 300°C: ±5°C	0.1°C	
	S *1					
	B *1	0.0 to 1820.0°C	400 to 600°C: ±2°C Less than 400°C: accuracy not guaranteed	400 to 600°C: ±7°C Less than 400°C: accuracy not guaranteed		
	K *1	-200.0 to 1370.0°C	±(0.05% of rdg. + 0.7°C) However, -200 to -100°C: ±(0.05% of rdg. + 1°C)	±(0.1% of rdg. + 3.5°C) However, -200 to -100°C: ±(0.1% of rdg. + 6°C)		
	E *1	-200.0 to 800.0°C	±(0.05% of rdg. + 0.5°C) However, J, L: -200 to -100°C: ±(0.05% of rdg. + 0.7°C)	±(0.1% of rdg. + 2.5°C) However, -200 to -100°C: ±(0.1% of rdg. + 5°C)		
	J *1	-200.0 to 1100.0°C				
	T *1	-200.0 to 400.0°C	±(0.05% of rdg. + 0.7°C)	±(0.1% of rdg. + 5°C)		
	L *2	-200.0 to 900.0°C				
	U	-200.0 to 400.0°C	±(0.05% of rdg. + 0.7°C)	±(0.1% of rdg. + 3.5°C)		
	N *3	0.0 to 1300.0°C				
	W *4	0.0 to 2315.0°C	±(0.05% of rdg. + 1°C)	±(0.1% of rdg. + 7°C)		
	KPvsAu7Fe	0.0 to 300.0 K	±(0.05% of rdg. + 0.7 K)	±(0.1% of rdg. + 3.5 K)		0.1 K
3-wire RTD (Measurement current 1 mA)	Pt100 *5	-200.0 to 600.0°C	±(0.05% of rdg. + 0.3°C)	±(0.1% of rdg. + 1.5°C)	0.1°C	
	JPt100 *5	-200.0 to 550.0°C				
	Pt100 (high resolution)	-140.00 to 150.00°C	±(0.05% of rdg. + 0.3°C)	±(0.1% of rdg. + 1.5°C)	0.01°C	
	JPt100 (high resolution)	-140.00 to 150.00°C				
	Ni100 SAMA *6	-200.0 to 250.0°C	±(0.05% of rdg. + 0.3°C)	±(0.1% of rdg. + 1.5°C)	0.1°C	
	Ni100 DIN *6	-60.0 to 180.0°C				
	Ni120 *7	-70.0 to 200.0°C				
	Pt50 *5	-200.0 to 550.0°C	±(0.1% of rdg. + 2°C)	±(0.2% of rdg. + 5°C)		
	Cu10 GE *8	-200.0 to 300.0°C				
	Cu10 L&N *8	-200.0 to 300.0°C				
	Cu10 WEED *8	-200.0 to 300.0°C				
	Cu10 BAILEY *8	-200.0 to 300.0°C	±(0.05% of rdg. + 0.3 K)	±(0.1% of rdg. + 1.5 K)	0.1 K	
J263B	0.0 to 300.0 K					
DI	Level	V _{th} = 2.4 V	Threshold level accuracy ±0.1 V			
	Non-voltage contact	1 kΩ or less: ON, 100 kΩ or more: OFF (parallel capacity is 0.01 μF or less) *9				

*1 R, S, B, K, E, J, T: ANSI, IEC 584, DIN IEC 584, JIS C 1602-1981

*2 L: Fe-CuNi, DIN43710/U: Cu-CuNi, DIN 43710

*3 N: Nicrosil-Nisil, IEC 584, DIN IEC 584

*4 W: W-5%RE-W-26%Re (Hoskins Mfg Co)

*5 Pt50: JIS C 1604-1981, JIS C 1606-1986/Pt100: JIS C 1604-1989, JIS C 1606-1989, IEC 751, DIN IEC 751/JPt100: JIS C 1604-1981, JIS C 1606-1989

*6 SAMA/DIN

*7 McGRAW EDISON COMPANY

*8 Guaranteed accuracy range Cu10 GE: -84.4 to 170.0°C/Cu10 L&N: -75.0 to 150.0°C/Cu10 WEED: -20.0 to 250.0°C/Cu10 BAILEY: -20.0 to 250.0°C

*9 To be determined at the measurement current of approximately 10 μA and within the range of 200 mV. The threshold level is approximately 0.1 V.

T08.EPS

Measurement Ranges and Accuracies (continued)

Input	Type	Rated measurement range	Measurement accuracy integral time 16.67 ms or more	Measurement accuracy integral time 1.67 ms	Maximum resolution (1 digit)
DC voltage	60 mV (high resolution)	0.000 to 60.000 mV	±(0.05% of rdg. + 20 digits)	±(0.1% of rdg. + 100 digits)	1 μV
	1 V	-1.0000 to 1.0000 V	±(0.05% of rdg. + 2 digits)	±(0.1% of rdg. + 10 digits)	100 μV
	6 V (high resolution)	0.0000 to 6.0000 V	±(0.05% of rdg. + 20 digits)	±(0.1% of rdg. + 100 digits)	100 μV
Thermocouple RJC accuracy not included	PLATINEL	0.0 to 1400.0°C	±(0.05% of rdg. + 1°C)	±(0.1% of rdg. + 4°C)	0.1°C
	PR40-20 *1	0.0 to 1900.0°C	±(0.05% of rdg. + 2.5°C) However, 300 to 700°C: ±6°C Less than 300°C: accuracy not guaranteed	±(0.1% of rdg. + 12°C) However, 300 to 700°C: ±25°C Less than 300°C: accuracy not guaranteed	
	NiNiMo	0.0 to 1310.0°C	±(0.05% of rdg. + 0.7°C)	±(0.1% of rdg. + 2.7°C)	
	WRe3-25	0.0 to 2400.0°C	±(0.05% of rdg. + 2°C) However, 0 to 200°C: ±2.5°C 2000°C or more: ±(0.05% of rdg. + 4°C)	±(0.1% of rdg. + 7°C) However, 0 to 200°C: ±12°C 2000°C or more: ±(0.1% of rdg. + 11°C)	
	W/WRe26	0.0 to 2400.0°C	±(0.05% of rdg. + 2°C) However, 100 to 300°C: ±4°C Less than 100°C: accuracy not guaranteed	±(0.1% of rdg. + 8.5°C) However, 100 to 300°C: ±12°C Less than 100°C: accuracy not guaranteed	
	Type-N (AWG14)	0.0 to 1300.0°C	±(0.05% of rdg. + 0.7°C)	±(0.1% of rdg. + 3.5°C)	
	TXK GOST	-200.0 to 600.0°C	±(0.05% of rdg. + 0.5°C) However, -200 to 0°C: ±(0.2% of rdg. + 0.7°C)	±(0.1% of rdg. + 2.5°C) However, -200 to 0°C: ±(1% of rdg. + 2.5°C)	
3-wire RTD (Measurement current 1 mA)	Cu10 at 20°C alpha=0.00392	-200.0 to 300.0°C	±(0.1% of rdg. + 2°C)	±(0.2% of rdg. + 5°C)	0.1°C
	Cu10 at 20°C alpha=0.00393	-200.0 to 300.0°C			
	Cu25 at 0°C alpha=0.00425	-200.0 to 300.0°C	±(0.1% of rdg. + 0.5°C)	±(0.2% of rdg. + 2°C)	0.1°C
	Cu53 at 0°C alpha=0.00426035	-50.0 to 150.0°C	±(0.05% of rdg. + 0.3°C)	±(0.1% of rdg. + 1.5°C)	0.1°C
	Cu100 at 0°C alpha=0.00425	-50.0 to 150.0°C			
	Pt25(JPt100×1/4)	-200.0 to 550.0°C	±(0.1% of rdg. + 0.5°C)	±(0.2% of rdg. + 2°C)	0.1°C
	Cu10 GE *2 (high resolution)	-200.0 to 300.0°C	±(0.1% of rdg. + 2°C)	±(0.2% of rdg. + 5°C)	0.1°C
	Cu10 L&N *2 (high resolution)	-200.0 to 300.0°C			
	Cu10 WEED *2 (high resolution)	-200.0 to 300.0°C			
	Cu10 BAILEY *2 (high resolution)	-200.0 to 300.0°C			
	Pt100 GOST	-200.0 to 600.0°C	±(0.05% of rdg. + 0.3°C)	±(0.1% of rdg. + 1.5°C)	0.1°C
	Cu100 GOST	-200.0 to 200.0°C	±(0.05% of rdg. + 0.3°C)	±(0.1% of rdg. + 1.5°C)	0.1°C
	Cu50 GOST	-200.0 to 200.0°C	±(0.05% of rdg. + 0.3°C)	±(0.1% of rdg. + 1.5°C)	0.1°C
Cu10 GOST	-200.0 to 200.0°C	±(0.1% of rdg. + 2°C)	±(0.2% of rdg. + 5°C)	0.1°C	

*1 PR40-20: PtRh20%-PtRh40% (John Matthey Plc)

*2 Guaranteed accuracy range Cu10 GE: -84.4 to 170.0°C/Cu10 L&N: -75.0 to 150.0°C/Cu10 WEED: -20.0 to 250.0°C/Cu10 BAILEY: -20.0 to 250.0°C

- Reference junction compensation:
External/internal switchover can be performed for each channel.
The Remote RJC function is available.
- Reference junction compensation accuracy:
During the measurement of 0°C or more and during the input terminal temperature balance
Type R, S, W: $\pm 1^\circ\text{C}$
Type K, J, E, T, N, L, U, TXK GOST: $\pm 0.5^\circ\text{C}$
PLATINEL, NiNiMo, WRe3-25, W/WRe26, N (AWG14): $\pm 1^\circ\text{C}$
Internal reference junction compensation for Type B and PR40-20 is fixed to 0°C.
- Maximum input voltage:
1 VDC range or less, thermocouple, RTD, DI (contact): ± 10 VDC
Other measurement ranges: ± 120 VDC
- Normal mode voltage:
DCV, TC, DI (level): 1.2 times of the rated range or less (50/60 Hz, peak values including signals)
RTD 100 Ω system: 50 mV peak
RTD 10, 25, 50 Ω systems: 10 mV peak
- Normal mode rejection ratio (NMRR):
40 dB or more when the integral time is 16.67 ms or more (50/60 Hz $\pm 0.1\%$)
50/60 Hz is not rejected when the integral time is 1.67 ms.
- Common mode voltage:
600 VACrms (50/60 Hz), reinforced (double) insulation
- Common mode rejection ratio (CMRR):
120 dB or more when the integral time is 16.67 ms or more
80 dB or more when the integral time is 1.67 ms
(50/60 Hz $\pm 0.1\%$, 500 Ω imbalance, between the minus measurement terminal and ground)
- Common mode voltage between channels:
120 VACrms (50/60 Hz)
- Noise rejection:
Rejection by an integrating A/D and the use of low pass filters
- Input resistance:
10 M Ω or more for the DC voltage of 1 V range or less and also for the thermocouple range
Approximately 1 M Ω if the DC voltage is in the 2 V range or more
- Insulation resistance:
20 M Ω or more between the input and ground (500 VDC)
- Input bias current:
10 nA or less (except when burn-out has been set)
- Withstand voltage:
1000 VACrms (50/60 Hz) between input terminals, one minute
3700 VACrms (50/60 Hz) between an input terminal and ground, one minute
- Input signal source resistance:
2 k Ω or less for DC voltage and thermocouple
10 Ω or less per cable for RTD 50 Ω or 100 Ω systems
1 Ω or less per cable for RTD 10 Ω or 25 Ω systems
- Thermocouple burn-out:
Checking of the burn-out at a detection cycle specified for each measurement interval, the up/down setting possible, 2 k Ω or less being normal, 200 k Ω or more being disconnected. Detection current shall be approximately 10 μA . Detection time shall be approximately 2 ms. Parallel capacity shall be 0.01 μF or less.
- Parallel capacity during RTD: 0.01 μF or less
- Power consumption: Approximately 1.2 W
- External dimension: Approximately 57 \times 131 \times 151 mm (including the terminal cover)
- Weight: Approximately 0.5 kg
- Terminal type: C lamp terminal. The plate with clamp terminals can be attached/detached.
- Applicable cable size: 0.14-1.5 mm² (AWG26-16)

Influence of operating conditions (applicable if the integral time is 16.67 ms or more)

Warm-up time: 30 minutes or more after the power supply is turned on.

Influence of ambient temperature:

Influence on a change in ambient temperature of 10°C is within $\pm(0.05\%$ of rdg. + 0.05% of range).

However, Cu10 Ω : $\pm(0.2\%$ of range + 1 digit)

Influence of power supply fluctuations:

Specifications of accuracy are satisfied at AC power 90-132 V or 180-250 V.

Influence of external magnetic fields:

Fluctuations of external magnetic fields of alternate current (50/60 Hz) 400 A/m is $\pm(0.1\%$ of rdg. + 10 digits) or less.

Influence of signal source resistance:

Influences on fluctuations of signal source resistance (1 k Ω) of voltage and thermocouple are:

Voltage: 1 V range or less

$\pm 10 \mu\text{V}$ or less

2 V range or more

$\pm 0.15\%$ of rdg. or less

Thermocouple: $\pm 10 \mu\text{V}$ or less

RTD: Fluctuation (one common resistance value for three cables) on a change of 10 Ω per cable for 100 Ω systems is $\pm 0.1^\circ\text{C}$ or less ($\pm 1.0^\circ\text{C}$ or less for other systems).

Fluctuation on the difference of 40 m Ω in resistance values among conductors (maximum difference among three cables) shall be approximately 0.1°C (for Pt100).

Influence of attitude:

Basically, the system shall be used in a horizontal position with its legs extended downward.

Influence of vibrations:

Fluctuations when sine wave vibrations in the frequency of 10-60 Hz and at an acceleration of 0.2 m/s² are applied for two hours respectively in three axis directions shall be $\pm(0.1\%$ of rdg. + 1 digit) or less.

• Six-Channel Medium-Speed 4-Wire RTD and Resistance Input Module (MX110-V4R-M06)

Style number: S2

Types of measurement: DC voltage, 4-wire RTD, 4-wire resistance, DI (non-voltage contact, LEVEL (5 V logic))

Number of measurement points: 6 (scanning of 6 channels with one A/D)

Input method: Floating unbalanced input, isolation between channels

A/D resolution: $\pm 20000/\pm 6000$ (16-bit A/D is used)

Measurement interval and A/D integral time: A/D integral time is determined by measurement interval.

Measurement interval	Integral time	Noise rejection /remarks
100 ms	1.67 ms ^(*1)	600 Hz and its integer multiples
200 ms		
500 ms	16.67 ms	60 Hz and its integer multiples
	20 ms	50 Hz and its integer multiples
	Auto ^(*2)	Power supply frequency is automatically detected and is set to 16.67/20 ms
1 s	36.67 ms	50/60 Hz and the respective integer multiples
2 s	100 ms ^(*3)	10 Hz and its integer multiples ^(*3)
5 s	200 ms ^(*4)	Fc = 5 Hz low pass filter ^(*4)
10, 20, 30, 60 s	200 ms	Fc = 5 Hz low pass filter

T10.EPS

(*1) If resistance measurements are taken at an integral time of 1.67 ms, the measured values may be susceptible to inaccuracies due to power supply frequency noise. If this is the case, set the integral time to 16.67 ms or longer (for a power supply frequency of 60 Hz), or 20 ms or longer (for a power supply frequency of 50 Hz). On this module, the power supply frequency noise can be rejected by selecting a measurement interval of 500ms or more. (on DAQMASTER, the integral time is automatically set when selecting the measurement interval.)

(*2) Set to 20 ms when using DC power.

(*3) When using the SNTP time synchronization function, the integral time is 36.67 ms. Also, in this case, noise of 50 Hz, 60 Hz, and their integer multiples are rejected.

(*4) When using the SNTP time synchronization function, the integral time is 100 ms. Also, in this case, noise of 10 Hz and its integer multiples are rejected.

Measurement Ranges and Accuracies

The accuracy applies to standard operating conditions: ambient temp: 23±2°C, ambient humidity: 55±10% RH, supply voltage: 90 to 250 VAC, power frequency: 50/60 Hz ± 1%, warm-up time: at least 30 minutes, without adverse conditions such as vibrations.

Input	Type	Rated measurement range	Measurement accuracy integral time 16.67 ms or more	Measurement accuracy integral time 1.67 ms	Maximum resolution (1 digit)
DC voltage	20 mV	-20.000 to 20.000 mV	±(0.05% of rdg. + 5 digits)	±(0.1% of rdg. + 25 digits)	1 μV
	60 mV	-60.00 to 60.00 mV	±(0.05% of rdg. + 2 digits)		±(0.1% of rdg. + 10 digits)
	200 mV	-200.00 to 200.00 mV		±(0.05% of rdg. + 5 digits)	
	2 V	-2.0000 to 2.0000 V	±(0.05% of rdg. + 2 digits)	±(0.1% of rdg. + 10 digits)	1 mV
	6 V	-6.000 to 6.000 V			10 mV
	20 V	-20.000 to 20.000 V			
	100 V	-100.00 to 100.00 V			
DI	Level	V _{th} = 2.4 V	Threshold level accuracy ±0.1 V		
	Non-voltage contact	1 kΩ or less: ON, 100 kΩ or more: OFF (parallel capacity is 0.01 μF or less) *1			
4-wire RTD (Measurement current 1 mA)	Pt100 *2	-200.0 to 600.0°C	±(0.05% of rdg. + 0.3°C)	±(0.1% of rdg. + 1.5°C)	0.1°C
	JPt100 *2	-200.0 to 550.0°C			0.01°C
	Pt100 (high resolution)	-140.00 to 150.00°C			
	JPt100 (high resolution)	-140.00 to 150.00°C			0.1°C
	Ni100 SAMA *3	-200.0 to 250.0°C			
	Ni100 DIN *3	-60.0 to 180.0°C			
	Ni120 *4	-70.0 to 200.0°C			
	Pt50 *2	-200.0 to 550.0°C			
	Cu10 GE *5	-200.0 to 300.0°C	±(0.1% of rdg. + 2°C)	±(0.2% of rdg. + 5°C)	0.1°C
	Cu10 L&N *5	-200.0 to 300.0°C			
	Cu10 WEED *5	-200.0 to 300.0°C			
	Cu10 BAILEY *5	-200.0 to 300.0°C			
	J263B	0.0 to 300.0 K	±(0.05% of rdg. + 0.3 K)	±(0.1% of rdg. + 1.5 K)	0.1 K
4-wire RTD (Measurement current 0.25 mA)	Pt500 *6	-200.0 to 600.0°C	±(0.05% of rdg. + 0.3°C)	±(0.1% of rdg. + 1.5°C)	0.1°C
	Pt1000 *6	-200.0 to 600.0°C			
4-wire resistance	20 Ω (measurement current: 1mA)	0.000 to 20.000 Ω	±(0.05% of rdg. + 7 digits)	±(0.1% of rdg. + 25 digits)	0.001 Ω
	200 Ω (measurement current: 1mA)	0.00 to 200.00 Ω	±(0.05% of rdg. + 3 digits)	±(0.1% of rdg. + 15 digits)	0.01 Ω
	2 kΩ (measurement current: 0.25mA)	0.0 to 2000.0 Ω	±(0.05% of rdg. + 3 digits)	±(0.1% of rdg. + 10 digits)	0.1 Ω

T11.EPS

*1 To be determined at the measurement current of approximately 10 μA and within the range of 200 mV. The threshold level is approximately 0.1 V.
 *2 Pt50: JIS C 1604-1981, JIS C 1606-1986/Pt100: JIS C 1604-1989, JIS C 1606-1989, IEC 751, DIN IEC 751/JPt100: JIS C 1604-1981, JIS C 1606-1989
 *3 SAMA/DIN
 *4 McGRAW EDISON COMPANY
 *5 Guaranteed accuracy range Cu10 GE: -84.4 to 170.0°C/Cu10 L&N: -75.0 to 150.0°C/Cu10 WEED: -20.0 to 250.0°C/Cu10 BAILEY: -20.0 to 250.0°C
 *6 The Pt500 resistance table is Pt100 × 5, and the Pt1000 resistance table is Pt100 × 10.

Measurement Ranges and Accuracies (continued)

Input	Type	Rated measurement range	Measurement accuracy integral time 16.67 ms or more	Measurement accuracy integral time 1.67 ms	Maximum resolution (1 digit)
DC voltage	60 mV (high resolution)	0.000 to 60.000 mV	$\pm(0.05\%$ of rdg. + 20 digits)	$\pm(0.1\%$ of rdg. + 100 digits)	1 μ V
	1 V	-1.0000 to 1.0000 V	$\pm(0.05\%$ of rdg. + 2 digits)	$\pm(0.1\%$ of rdg. + 10 digits)	100 μ V
	6 V (high resolution)	0.0000 to 6.0000 V	$\pm(0.05\%$ of rdg. + 20 digits)	$\pm(0.1\%$ of rdg. + 100 digits)	100 μ V
4-wire RTD (Measurement current 1 mA)	Cu10 at 20°C alpha=0.00392	-200.0 to 300.0°C	$\pm(0.1\%$ of rdg. + 2°C)	$\pm(0.2\%$ of rdg. + 5°C)	0.1°C
	Cu10 at 20°C alpha=0.00393	-200.0 to 300.0°C			
	Cu25 at 0°C alpha=0.00425	-200.0 to 300.0°C	$\pm(0.1\%$ of rdg. + 0.5°C)	$\pm(0.2\%$ of rdg. + 2°C)	0.1°C
	Cu53 at 0°C alpha=0.00426035	-50.0 to 150.0°C	$\pm(0.05\%$ of rdg. + 0.3°C)	$\pm(0.1\%$ of rdg. + 1.5°C)	0.1°C
	Cu100 at 0°C alpha=0.00425	-50.0 to 150.0°C			
	Pt25(JPt100×1/4)	-200.0 to 550.0°C	$\pm(0.1\%$ of rdg. + 0.5°C)	$\pm(0.2\%$ of rdg. + 2°C)	0.1°C
	Cu10 GE *1 (high resolution)	-200.0 to 300.0°C	$\pm(0.1\%$ of rdg. + 2°C)	$\pm(0.2\%$ of rdg. + 5°C)	0.1°C
	Cu10 L&N *1 (high resolution)	-200.0 to 300.0°C			
	Cu10 WEED *1 (high resolution)	-200.0 to 300.0°C			
	Cu10 BAILEY *1 (high resolution)	-200.0 to 300.0°C			
	Pt100 GOST	-200.0 to 600.0°C	$\pm(0.05\%$ of rdg. + 0.3°C)	$\pm(0.1\%$ of rdg. + 1.5°C)	0.1°C
	Cu100 GOST	-200.0 to 200.0°C	$\pm(0.05\%$ of rdg. + 0.3°C)	$\pm(0.1\%$ of rdg. + 1.5°C)	0.1°C
	Cu50 GOST	-200.0 to 200.0°C	$\pm(0.05\%$ of rdg. + 0.3°C)	$\pm(0.1\%$ of rdg. + 1.5°C)	0.1°C
Cu10 GOST	-200.0 to 200.0°C	$\pm(0.1\%$ of rdg. + 2°C)	$\pm(0.2\%$ of rdg. + 5°C)	0.1°C	

*1 Guaranteed accuracy range Cu10 GE: -84.4 to 170.0°C/Cu10 L&N: -75.0 to 150.0°C/Cu10 WEED: -20.0 to 250.0°C/Cu10 BAILEY: -20.0 to 250.0°C

Maximum input voltage: 1 VDC range or less/RTD/resistance/DI (contact): ± 10 VDC (continuous)
 Other measurement ranges: ± 120 VDC (continuous)

Normal mode voltage:

- VDC, DI (LEVEL): 1.2 times the rated range or less (50/60 Hz, peak values including signals)
- 2 k Ω resistance, RTD 100/500/1000 Ω systems: 50 mV peak
- 200 Ω resistance, RTD 10/25/50 Ω systems: 10 mV peak
- 20 Ω resistance: 4 mV peak

Normal-mode rejection ratio (NMRR):

- 40 dB or more (50/60 Hz $\pm 0.1\%$) when the integral time is 16.67 ms or more.
- 50/60 Hz is not rejected when the integral time is 1.67 ms.

Common mode voltage: 600 VACrms (50/60Hz), reinforced (double) insulation

Common-mode rejection ratio (CMRR):

- 120 dB or more when the integral time is 16.67 ms or more. 80 dB or more when the integral time is 1.67 ms.
- 50/60 Hz $\pm 0.1\%$, 500 Ω imbalance (for voltage), between the minus measurement terminal and ground, (In the RTD and resistance ranges, CMRR is calculated by the voltage conversion values while the measured current is applied).

Common mode voltage between channels: 120 VACrms (50/60 Hz) for DCV/DI

50 VACrms (50/60 Hz) for RTD/resistance

Noise rejection: Rejection by the integrating A/D and the use of low pass filters.

Input resistance: 10 M Ω or more at the 1 VDC range or lower.

Approximately 1 M Ω at the 2 VDC range or higher.

Insulation resistance: 20 M Ω or more between an input terminal and ground (500 VDC)

Input bias current: 10 nA or less

Withstanding voltage:

Between input terminals (DCV or DI range), 1000 VACrms (50/60 Hz) for one minute

Between input terminals (RTD or resistance range), 620 VACrms (50/60 Hz) for one minute

Between an input terminal and ground, 3700 VACrms (50/60 Hz) for one minute

Input signal source resistance:

2 k Ω or less for DCV range

10 Ω or less per cable for the resistance and RTD ranges (common for all ranges)

Allowable parallel capacity: 0.01 μ F or less (when using the resistance or RTD range)

Power consumption: Approximately 1.2 W

External dimension: Approximately 57 \times 131 \times 151 mm (including the terminal cover)

Weight: Approximately 0.5 kg

Terminal type: Clamp terminal. The plate with clamp terminals can be attached/detached.

Applicable cable size: 0.14-1.5 mm² (AWG26-16)

Influence of operating conditions (applicable if the integral time is 16.67 ms or more)

Warm-up time: 30 minutes or more after the power supply is turned on.

Influence of ambient temperature: Influence on a change in ambient temperature of 10°C is within $\pm(0.05\%$ of rdg. + 0.05% of range). However, Cu10 Ω : $\pm(0.2\%$ of range + 1 digit)

Influence of power supply fluctuations: Specifications of accuracy are satisfied at AC power 90-132 V or 180-250 V.

Influence of external magnetic fields: Fluctuations of external magnetic fields of alternate current (50/60 Hz) 400A/m is $\pm(0.1\%$ of rdg. + 10 digits) or less

Influence of signal source resistance:

Influences on fluctuations of signal source resistance (1 k Ω) of voltage are:

1 V range or lower: ± 10 μ V or less

2 V range or more: $\pm 0.15\%$ of rdg. or less

Fluctuations on a change of 10 Ω per resistance temperature detector cable are:

1000 Ω , or 100 Ω systems: $\pm 0.1^\circ$ C or less

Other systems: $\pm 1.0^\circ$ C or less

Fluctuations on a change of 10 Ω per resistance cable are within ± 1 digit.

Influence of attitude:

Basically, the system shall be used in a horizontal position with its legs extended downward.

Influence of vibration:

Fluctuations when sine wave vibrations in the frequency of 10-60 Hz and at an acceleration of 0.2 m/s² are applied for two hours respectively in three axis directions shall be $\pm(0.1\%$ of rdg. + 1 digit) or less.

• Four-Channel Medium-Speed Strain Input Module (MX112-xxx-M04)

Style number: S2

Types of measurement: Strain gauge or strain gauge sensor (static strain)

Number of measurement points: 4 (scanning of 4 channels with one A/D)

Input method: Floating balanced input

A/D resolution: ±20000 (16-bit A/D is used), except for an integral time of 1.67 ms

Measurement interval and A/D integral time: A/D integral time is determined by measurement interval.

Measurement interval	Integral time	Noise rejection /remarks
100 ms	1.67 ms ^(*1)	600 Hz and its integer multiples
200 ms	16.67 ms	60 Hz and its integer multiples
	20 ms	50 Hz and its integer multiples
	Auto ^(*2)	Power supply frequency is automatically detected and is set to 16.67/20 ms
500 ms	36.67 ms	50/60 Hz and the respective integer multiples
1 s	100 ms	10 Hz and its integer multiples
2 s	200 ms ^(*3)	Fc = 5 Hz low pass filter ^(*3)
5, 10, 20, 30, 60 s	200 ms	Fc = 5 Hz low pass filter

T13.EPS

(*1) If strain measurements are taken at an integral time of 1.67 ms, the measured values may be susceptible to inaccuracies due to power supply frequency noise. If this is the case, set the integral time to 16.67 ms or longer (for a power supply frequency of 60 Hz), or 20 ms or longer (for a power supply frequency of 50 Hz). On this module, the power supply frequency noise can be rejected by selecting a measurement interval of 200ms or more. (on DAQMASTER, the integral time is automatically set when selecting the measurement interval.)

(*2) Set to 20 ms when using DC power.

(*3) When using the Sntp time synchronization function, the integral time is 100 ms. Also, in this case, noise of 10 Hz and its integer multiples are rejected.

Gauge connection method:

Single-gauge (2 or 3 wire), opposed-side two-gauge, adjacent-side two-gauge or four-gauge.

In the case of -B12 and -B35, set the connection method using the DIP switch on the module. -B12 and -B35 allow DIP switch setting by channel.

Applicable gauge resistance:

100 to 1000Ω.

Built-in resistance of 120 Ω for -B12, and 350 Ω for -B35

Bridge voltage: 2 VDC fixed (accurate to ±5 %)

Applicable gauge factor: 2.0 fixed, gauge factor correction possible with scaling function

Balance adjustment: Automatic (digital computation method)

Balance adjustment range: ±10,000 μ strain (for single-gauge method)

Balance adjustment accuracy: Less than or equal to the measurement accuracy

Measurement ranges and accuracies (single-gauge method conversion, other gauge methods use conversion by scaling):

The accuracy applies to standard operating conditions: ambient temp: 23±2°C, ambient humidity: 55±10% RH, supply voltage: 90 to 250 VAC, power frequency: 50/60 Hz ± 1%, warm-up time: at least 30 minutes, without adverse conditions such as vibrations.

Measurement range	Measuring range	Integral time 16.67 ms or more		Integral time 1.67 ms	
		Measurement accuracy	Resolution	Measurement accuracy	Resolution
2000 μ strain	± 2000 μ strain	± 0.5% of range	0.1 μ strain	2% of range	1 μ strain
20000 μ strain	± 20000 μ strain	± 0.3% of range	1 μ strain	1% of range	2 μ strain
200000 μ strain	± 200000 μ strain	± 0.3% of range	10 μ strain	1% of range	10 μ strain

T14.EPS

Bridge resistance accuracy (-B12, -B35): ±0.01% ±5 ppm/°C

Input resistance: 1 MΩ or more

Allowable wiring resistance: 100 Ω or less

Influence of wiring resistance:

For -B12 and -B35, the wiring resistance component is not corrected.

Depends on the gauge resistance.

For -NDI, 50 ppm of rdg./ Ω (when using remote sense wires)

Temperature coefficient: ± 100 ppm of range/ $^{\circ}\text{C}$

Allowable input voltage: ± 10 VDC (between H-L) continuous

Common mode voltage:

-B12, -B35: Between channels: 30 VACrms (50/60 Hz)

Between an input terminal and ground: 250 VACrms (50/60 Hz)

-NDI: Between channels: 30 VACrms (50/60 Hz)

Between an input terminal and ground: 30 VACrms (50/60 Hz)

(the connector shell is connected to earth potential.)

Common-mode rejection ratio (CMRR), (-NDI is not applicable.):

120 dB or more when the integral time is 16.67 ms or more. (50/60 Hz $\pm 0.1\%$)

80 dB or more when the integral time is 1.67 ms. (50/60 Hz $\pm 0.1\%$)

(voltage conversion value given a bridge voltage of 2 V)

Normal-mode rejection ratio (NMRR):

40 dB or more (50/60 Hz $\pm 0.1\%$) when the integral time is 16.67 ms or more.

50/60 Hz is not rejected when the integral time is 1.67 ms.

(voltage conversion value given a bridge voltage of 2 V).

Influence of external magnetic fields: Fluctuations of external magnetic fields of alternate current (50/60 Hz) 400 A/m is $\pm 2\%$ of range or less (measurement interval of 200 ms or more).

Insulation resistance (-NDI is not applicable.):

Between an input terminal and ground, 20 M Ω or more (500 VDC)

Withstanding voltage (-NDI is not applicable.):

Between an input terminal and ground, 2300 VACrms (50/60 Hz) for one minute

Between channels, 30 VACrms or less

Terminal type:

-B12, -B35: Clamp terminal (the plate with clamp terminals can be attached/detached.)

-NDI: NDIS connector

Applicable cable size (-B12, -B35): 0.14-1.5 mm² (AWG26-16)

Power consumption: Approximately 3 W

External dimension: Approximately 57 × 131 × 151 mm (including the terminal cover)

Weight: Approximately 0.5 kg

• Ten-Channel High-Speed 5 V Digital Input Module (MX115-D05-H10)

Style number: S1

Input type: Non-voltage contact, level (5 V logic), open collector

Number of channels: 10

Input format: Pull-up at approximately 5 V/approximately 5 kΩ. No isolation between channels

Measurement interval: 10/50/100/200/500 ms, 1/2/5/10/20/30/60 s

Filter: Measurement interval of 5 s or less: Uses the widest ON/OFF width during the detection period (approximately 75% to 90% of the measurement interval).

Measurement interval of 5 s or more: Uses the widest ON/OFF width during approximately 4.5 s

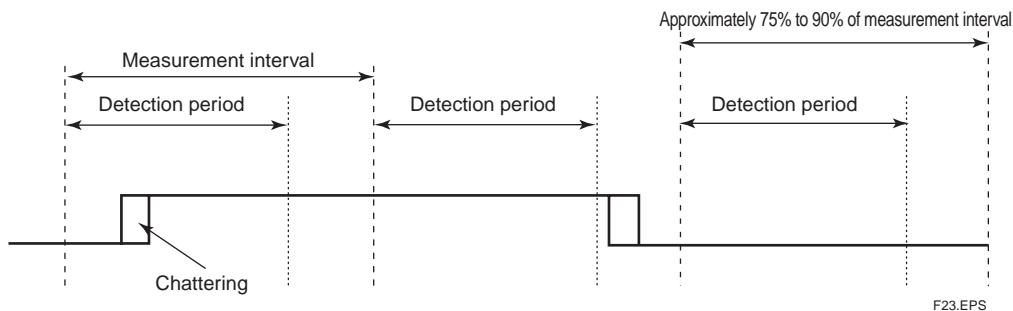

If a measurement interval is set to four times or more of the chattering continuation time, measurement can be performed without being influenced by chattering. (Reference information: The chattering of the general relays is approximately 20 ms.)

Minimum detection pulse width: two times or more of a measurement interval

Input threshold level:

Non-voltage contact, open collector: "On" for 100 Ω or less, "Off" for 100 kΩ or more

Level (5 V logic): "Off" for 1 V or less, "On" for 3 V or more

Hysteresis width: Approximately 0.1 V

Contact, rated transistor:

Rated contact with 15 VDC or more and 30 mA or more

Rated transistor with Vce > 15 Vdc and Ic > 30 mA

Maximum input voltage: 10 VDC

Common mode voltage: 250 VACrms (50/60Hz) between an input terminal and ground

Insulation resistance:

20 MΩ or more (500 VDC) between an input terminal and ground

Withstand voltage: 2300 VACrms (50/60Hz) between an input terminal and ground, one minute

Power consumption: Approximately 1.5 W

External dimension: Approximately 57 × 131 × 151 mm (including the terminal cover)

Weight: Approximately 0.5 kg

Terminal type: Clamp terminal. The plate with clamp terminals can be attached/detached.

Applicable cable size: 0.14-1.5 mm² (AWG26-16)

• Ten-Channel High-Speed 24 V Digital Input Module (MX115-D24-H10)

Style number: S2

Input type: Level (24 V logic), No isolation between channels

Number of channels: 10

Measurement interval: 10/ 50/100/200/500 ms, 1/2/5/10/20/30/60 s

Filter: Measurement interval of 5 s or less: Uses the widest ON/OFF width during the detection period (approximately 75% to 90% of the measurement interval).

Measurement interval of 5 s or more: Uses the widest ON/OFF width during approximately 4.5 s

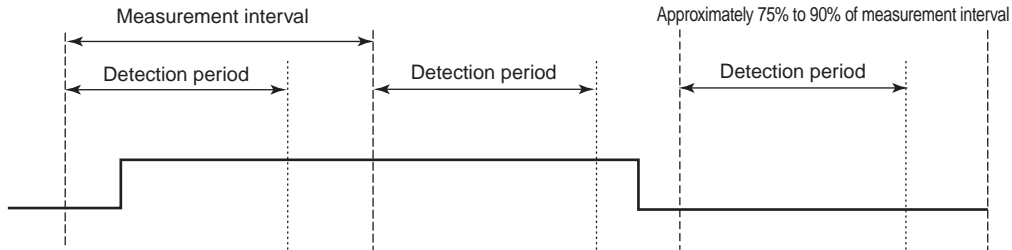

F24.EPS

Input resistance: Approximately 200 kΩ (between + and – terminals)

Maximum input voltage: 50 VDC

Minimum detection pulse width: two times the measurement interval or more

Input threshold level: "Off" for 6 V or less, "ON" for 16 V or more

Hysteresis width: Approximately 1.5 V

Common mode voltage: 250 VACrms (50/60Hz) between an input terminal and ground

Insulation resistance: 20 MΩ or more between an input terminal and ground (500 VDC)

Withstand voltage: 2300 VACrms (50/60Hz) between an input terminal and ground, one minute

Power consumption: Approximately 1.5 W

External dimension: Approximately 57 × 131 × 151 mm (including the terminal cover)

Weight: Approximately 0.5 kg

Terminal type: Clamp terminal. The plate with clamp terminals can be attached/detached.

Applicable cable size: 0.14-1.5 mm² (AWG26-16)

• Eight-Channel Medium-Speed Analog Output Module (MX120-VAO-M08)

Style number: S2

Number of output points: 8

Output types: DC voltage, DC current (allows mixed voltage and current output)

Output data:

Command output: Output of set values is carried out by communication input (communication commands or browser requests) from the PC.

Retransmission output: Measured values and computed values within the same unit are scaled and output. Output is continuous even when communications are cut as the operation is performed inside the main module.

Other Output:

Output during power cycle:

Outputs from the time the power is turned ON until measurement starts or a command is received. Previous values (values active at the time the power was last turned OFF), or preset values can be selected for output.

Output during abnormalities (errors):

Outputs when input values for transmission output are erroneous or the CPU is down. Previous values (values active just prior to the abnormality), or preset values can be selected for output.

Output during \pm over:

Output occurs at $\pm 5\%$ of the output setting span when the input values for transmission output are \pm over. (However, the available output range is -11 V to 11 V (voltage) and 0 - 20 mA (current)).

Note 1) Preset values: Specified values can be set one per channel. However, preset values during power cycle or abnormality (error) are the same. The available setting range is -11 V to 11 V (voltage) and 0 to 22 mA (current)).

Note 2) Preset and previous values are stored in the module.

Output update cycle: 100 ms

Rated output range: Voltage: -10 to 10 V, current: 0 to 20 mA, sourcing (4 to 20 mA is output at 1 to 5 V output)

When the voltage is set to 5.5 V or higher, the current output is clipped at approximately 22 mA.

Maximum allowable output range: Voltage: -11 to 11 V, current: 0 to 22 mA

Load resistance: Voltage: 5 k Ω or more, current: 600 Ω or less

Accuracy (at rated output): $\pm 0.2\%$ of F.S. (F.S.= 10 V or 20 mA). However, for current output, accuracy is met at 1 mA or more. The accuracy applies to standard operating conditions: ambient temp: $23 \pm 2^\circ\text{C}$, ambient humidity: $55 \pm 10\%$ RH, supply voltage: 90 to 250 VAC, power frequency: $50/60$ Hz $\pm 1\%$, warm-up time: at least 30 minutes, without adverse conditions such as vibrations.

Output resolution: 12 bit of F.S. or more

The relationship between the output voltage/current value and the internal count value (designed center value)

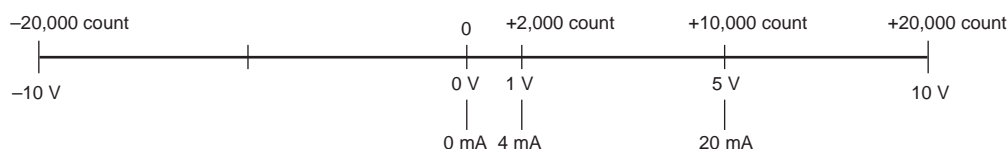

F28.EPS

The setting resolution is as follows.

-10.000 V to 10.000 V (1 mV resolution)

0.000 mA to 20.000 mA (1 μ A resolution)

Influence of ambient temperature: Per 1°C , $\pm(50$ ppm of setting + 50 ppm of F.S.) or less (F.S. = 10 V or 20 mA)

External power supply (used for current output): 24 V $\pm 10\%$ and current capacity of 250 mA or more.

(Use of external power supplies is not necessary with only voltage output)

Common mode voltage: Between an output terminal and ground, 250 VACrms ($50/60$ Hz)

Insulation resistance:

Between an output terminal and ground, 20 M Ω or more (500 VDC)

Between output terminals, non-isolated (minus terminals share common potential)

Withstanding voltage:

Between an output terminal and ground, 2300 VACrms ($50/60$ Hz) for one minute

Between output terminals, non-isolated (minus terminals share common potential)

Power consumption: Approximately 2.5 W (excluding power consumption of external voltage sources)

External dimension: Approximately $57 \times 131 \times 151$ mm (including the terminal cover)

Weight: Approximately 0.5 kg

Terminal type: Clamp terminal (detachable every 4 channels)

Applicable cable size: 0.08 - 2.5 mm² (AWG28-12)

Note: The RJC accuracy of an universal input module may be influenced if placed to the left-side of this module.

• Eight-Channel Medium-Speed PWM Output Module (MX120-PWM-M08)

Style number: S2

Number of output points: 8

Pulse (output) interval: 1 ms to 30 s (1 ms interval setting range, set in 1 ms units per channel)
10 ms to 300 s (10 ms interval setting range, set in 10 ms units per channel)

Pulse interval accuracy: ± 100 ppm of setting value

Output update cycle: 100 ms

Update timing: Duty is updated from the falling edge of the next cycle after receiving the update command.

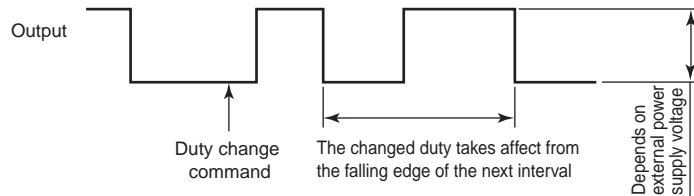

F25.EPS

Duty resolution: 1 ms interval setting range: 1/12000, 10 ms interval setting range: 1/60000
The setting resolution is as follows. However, output is at the hardware resolution above.
0-100.000% (0.001% resolution)

Duty accuracy (at load resistance of 100 Ω or less):

For 1 ms interval setting range, $\pm 0.017\%$ or $\pm 2 \mu\text{s}$ whichever is longer.

For 10 ms interval setting range, $\pm 0.0035\%$ or $\pm 2 \mu\text{s}$ whichever is longer.

When the load resistance is higher than 100 Ω , the output Duty may vary from the specification.

Output data:

Command output: Output of set values is carried out by communication input (communication commands or browser requests) from the PC.

Retransmission output: Measured values and computed values within the same unit are scaled and output. Output is continuous even when communications are cut as the operation is performed inside the main module.

Other Output:

Output during power cycle:

Outputs from the time the power is turned ON until measurement starts or a command is received.

Previous values (values active at the time the power was last turned OFF), or preset values can be selected for output.

Output during abnormalities (errors):

Outputs when input values for transmission output are erroneous or the CPU is down. Previous values (values active just prior to the abnormality), or preset values can be selected for output.

Output during \pm over:

Output occurs at $\pm 5\%$ of the output setting span when the input values for transmission output are \pm over. (However, the lower limit is 0% and the upper limit is 100%)

Note 1) Preset values: Specified values can be set one per channel. However, preset values during power cycle or abnormality (error) are the same. The available setting range is 0-100%.

Note 2) Preset and previous values are stored in the module.

Output format: External power supply sourcing

ON resistance: 2 Ω or less (when the output current is 200 mA or more)

External power supply: 4 V to 28 V

Output capacity: Max 1 A/ch, however, the total of one module is 4 A or less (approximately 1 A current limit circuit built-in)

Note 1) A current limit circuit of approximately 1 A is built in to the output circuit. Once the current limit circuit turns ON, the limit circuit continues to operate unless the external power supply is turned OFF (holds the output OFF condition). Once the external power supply is turned OFF, check the load condition before restarting it again.

Note 2) This module has a built-in fuse. The built-in fuse protects the instrument from fires or abnormal emission of heat during load shortages or other abnormalities, but does not prevent damage to the internal circuit element.

Common mode voltage: 250 VACrms (50/60Hz) between an output terminal and ground

Insulation resistance: Between an output terminal and ground, 20 M Ω or more (500 VDC)

Between output terminals, non-isolated

Withstanding voltage: Between an output terminal and ground, 2300 VACrms (50/60 Hz) for one minute

Between output terminals, non-isolated

Power consumption: Approximately 2.5 W (excluding power consumption of external voltage sources)

External dimension: Approximately 57 \times 131 \times 151 mm (including the terminal cover)

Weight: Approximately 0.5 kg

Terminal type: Clamp terminal (detachable every 4 channels)

Applicable cable size: 0.08-2.5 mm² (AWG28-12)

Note: The RJC accuracy of an universal input module may be influenced if placed to the left-side of this module.

• Ten-Channel Medium-Speed Digital Output Module (MX125-MKC-M10)

- Style number: S1
- Output types: Alarm output, command output, failure output, error output, low free space on media error output (insufficient space on media)
- Number of output points: 10
- Contact mode: "A" contact (SPST)
- Output update cycle: output per 100 ms (not synchronized with measurement intervals)
- Contact capacity: 250 VDC/0.1 A, 250 VAC/2 A, 30 VDC/2 A (resistance load)
- Contact lifespan: Approximately 100,000 times at the rated load. Approximately 20,000,000 times with no load. The contact life depends on load and operating conditions.
- Common mode voltage: 250 VACrms (50/60 Hz) between an output terminal and ground
- Insulation resistance:
- 20 M Ω or more (500 VDC) between an output terminal and ground
 - 20 M Ω or more (500 VDC) between output terminals
- Withstand voltage: 2300 VACrms (50/60 Hz) between an output terminal and ground, one minute
- 2300 VACrms (50/60 Hz) between output terminals, one minute
- Power consumption: Approximately 2 W (when all relays are turned on)
- External dimension: Approximately 57 × 131 × 151 mm (including the terminal cover)
- Weight: Approximately 0.5 kg
- Terminal type: Clamp terminal (detachable every 5 channels)
- Applicable cable size: 0.08-2.5 mm² (AWG28-12)
- Others: The excitation/non-excitation switchover and the hold/non-hold switchover are available.

■ PC software specifications

- **MW100 viewer software (attached to the main module of MW100)**
- **Release number:** R2.04 or later
- **Address setting software (main functions):**
Entering of initial communication settings such as IP address
- **Viewer (main functions):**
Re-display of saved data files, 32 channels in one group, 50 groups, file merge display (limited to files that can be merged), multi-interval supported (If channels with different intervals are assigned to the same group, windows are split (up to four splits) and displayed.), graph, digital display/print, cursor value display, interval arithmetic, alarm display, mark display, alarm/mark search, file information display, tag, tag comment, channel display switchover, data formatting conversion (conversion to ASCII, Excel, or Lotus format), etc.
- **Calibration software (main function): calibration function**
- **Operating environment**
CPU: Intel Pentium II 400 MHz or more (recommended: Pentium III and 1 GHz or more)
Memory: 256 MB or more (recommended: 512 MB or more)
OS: Windows 2000/XP (recommended)
Hard disk capacity: Free space of 50 MB or more (recommended: Hard disk with free space of 1 GB or more that operates at maximum speed)
Communication interface: Ethernet that can be used for Windows (recommended: 10 Base-T supported)
CD-ROM drive: CD-ROM drive that can be used for Windows (to be used for installation)
Printer: printer that can be used for Windows (to be used for printing)

■ Model Name

Main Module

Model	Suffix Code	Option Code	Description
MW100			Main module (with MW100 Viewer Software) *1, 2
Language	-E		English (with English user's manual) *3
Power supply voltage	-1		100 VAC-240 VAC
	-2		12 VDC-28 VDC, with AC adapter *4
	-3		12 VDC-28 VDC, without AC adapter *5
Power supply inlet and power supply cord	D		AC power: 3-pin power inlet with UL/CSA cable DC power: Screw terminal, UL/CSA cable for AC adapter
	F		AC power: 3-pin power inlet with VDE cable DC power: Screw terminal, VDE cable for AC adapter
	R		AC power: 3-pin power inlet with SAA cable DC power: Screw terminal, SAA cable for AC adapter
	Q		AC power: 3-pin power inlet with BS cable DC power: Screw terminal, BS cable for AC adapter
	H		AC power: 3-pin power inlet with GB (CCC) cable DC power: Screw terminal, GB (CCC) cable for AC adapter
	W		Screw terminal, power supply cord not included *4, 5
Options		/C2	RS-232 communications interface *6, 7
		/C3	RS-422A/485 communication interface *6, 7
		/M1	MATH function *7, 8

T15.EPS

*1: CF card does not come standard.

*2: Modbus/TCP server function comes standard.

*3: Displays Celsius or Fahrenheit, Winter/Summer time can be set.

*4: W cannot be selected with -2

*5: -3 can only be selected with W

*6: /C2 and /C3 may not be selected together

*7: /C2 or /C3 must be selected to use the Modbus/RTU slave function. Also, /M1 must be selected for use of the Modbus/RTU master function.

*8: /M1 must be selected to use the Modbus/TCP client function.

Input/Output Module

Model	Suffix Code	Option Code	Description
MX110			Analog input module
Input type	-UNV		DCV/TC/DI/3-wire RTD *1
	-V4R		DCV/DI/4-wire RTD/4-wire resistance *1
Measurement interval, number of channels	-H04		4 channels, high speed (shortest measurement interval: 10 ms)
	-M06		6 channels, medium speed (shortest measurement interval: 100 ms) *1
	-M10		10 channels, medium speed (shortest measurement interval: 100 ms) *2
Option		/NC	The plate with clamp terminals is not attached. *2

T16.EPS

*1: "-M06" must be specified when "-V4R" is specified.

"-M06" can not be specified when "-UNV" is specified.

*2: "/NC" can be specified only when "-M10" is specified.

Model	Suffix Code	Description
MX112		Strain input module
Input type	-B12	Built-in bridge resistance: 120 Ω
	-B35	Built-in bridge resistance: 350 Ω
	-NDI	For connection to external bridge head and strain gauge type sensor (NDIS connector)
Measurement interval, number of channels	-M04	4 channels, Medium speed (Shortest measurement interval: 100 ms)

T17.EPS

Model	Suffix Code	Option Code	Description
MX115			Digital input module
Input type	-D05		Non-voltage contact, 5 V logic, open collector
	-D24		24 V logic
Measurement interval, number of channels	-H10		10 channels, high speed (shortest measurement interval: 10 ms)
Option		/NC	The plate with clamp terminals is not attached.

T18.EPS

Model	Suffix Code	Description
MX120		Analog output module
Output type	-VAO	Voltage/Current output (allows mixed voltage and current output)
	-PWM	Pulse width modulation output
Measurement interval, number of channels	-M08	8 channels, output update cycle: 100 ms

T19.EPS

Model	Suffix Code	Description
MX125		Digital output module
Output type	-MKC	"A" contact (SPST)
Output update cycle, number of channels	-M10	10 channels, output update cycle: 100 ms

T20.EPS

Model	Suffix Code	Description
MX150		Base plate
Base type	-1	For connection with one main module and one input/output module
	-2	For connection with one main module and two input/output module
	-3	For connection with one main module and three input/output modules
	-4	For connection with one main module and four input/output modules
	-5	For connection with one main module and five input/output modules
	-6	For connection with one main module and six input/output modules

T21.EPS

Accessories

Model	Description
772061	Ten-Channel Screw (M4) Terminal Block (RJC included)

T23.EPS

Note: The 772061 model is applicable only to the MX110-UNV-M10 (Ten-Channel Medium-Speed Universal Input Module), the MX115-D05-H10 (Ten-Channel High-Speed 5 V Digital Input Module) or the MX115-D24-H10 (Ten-Channel High-Speed 24 V Digital Input Module).

Model	Suffix Code	Description
772062		Cable for connection between the input module and the screw terminal block
Cable length	-050	50 cm cable
	-100	100 cm cable

T24.EPS

Note: The 772062 model is applicable only between the MX110-UNV-M10 (Ten-Channel Medium-Speed Universal Input Module) and the Screw Terminal Block (772061), between the MX115-D05-H10 (Ten-Channel High-Speed 5 V Digital Input Module) and the Screw Terminal Block (772061) or between the MX115-D24-H10 (Ten-Channel High-Speed 24 V Digital Input Module) and the Screw Terminal Block (772061).

Model	Description
772063	Plate with clamp terminals (RJC included)

T25.EPS

Note: The 772063 model is applicable only to the MX110-UNV-M10 (Ten-Channel Medium-Speed Universal Input Module), the MX115-D05-H10 (Ten-Channel High-Speed 5 V Digital Input Module) or the MX115-D24-H10 (Ten-Channel High-Speed 24 V Digital Input Module).

Model	Description
772064	Clamp terminals

T26.EPS

Note: The 772064 model is applicable only to the MX110-UNV-H04 (Four-Channel High-Speed Universal Input Module).

Model	Description
772065	Clamp terminals

T27.EPS

Note: The 772065 model is applicable only to the MX120-VAO-M08 (Eight-Channel Medium-Speed Analog Output Module), the MX120-PWM-M08 (Eight-Channel Medium-Speed PWM Output Module) or the MX125-MKC-M10 (Ten-Channel Medium-Speed Digital output Module).

Model	Description
772066	Connector cover for base plate

T28.EPS

Model	Description
772067	Plate with clamp terminals

T29.EPS

Note: The 772067 model is applicable only to the MX110-V4R-M06 (Six-Channel Medium-Speed 4-Wire RTD and Resistance Input Module).

Model	Description
772068	Plate with clamp terminals (Built-in bridge resistance of 120 Ω)

T30.EPS

Note: The 772068 is applicable only to the MX112-B12-M04 (Four-Channel Medium Speed Strain Input Module, 120 Ω), or the MX112-B35-M04 (Four-Channel Medium Speed Strain Input Module, 350 Ω).

Model	Description
772069	Plate with clamp terminals (Built-in bridge resistance of 350 Ω)

T31.EPS

Note: The 772069 is applicable only to the MX112-B35-M04 (Four-Channel Medium Speed Strain Input Module, 350 Ω), or the MX112-B12-M04 (Four-Channel Medium Speed Strain Input Module, 120 Ω).

Model	Description
772080	Screw (M3) terminal plate (with RJC)

Note 1: The 772080 is applicable only to the MX110-UNV-M10 (Ten-Channel Medium Speed Universal Input Module), the MX115-D05-H10 (Ten-Channel High Speed 5 V DI Module), and the MX115-D24-H10 (Ten-Channel High Speed 24 V DI Module). T34.EPS

Note 2: Terminal cover included

Note 3: b terminals for RTD are common (2 terminals)

Model	Basic Suffix Code	Description
772075		AC adapter
Power supply cord	-D	Cable for UL/CSA
	-F	Cable for VDE
	-R	Cable for SAA
	-Q	Cable for BS
	-H	Cable for GB (CCC)

T35.EPS

Description	Model	Specifications
Adapter for CompactFlash card	772090	
CompactFlash card	772091	128 MB *1
CompactFlash card	772092	256 MB *1
CompactFlash card	772093	512 MB *1
CompactFlash card	772094	1 GB *1

*1: Operating temperature range: -40°C to 85°C

T36.EPS

Accessories

Name	Model	Specifications
Shunt Resistance (for clamp terminals)	438920	250Ω ± 0.1%
	438921	100Ω ± 0.1%
	438922	10Ω ± 0.1%
Shunt Resistance (for screw (M4) terminals)	415920	250Ω ± 0.1%
	415921	100Ω ± 0.1%
	415922	10Ω ± 0.1%

T32.EPS

Application Software

Model	Description
MW180	MW100 Viewer Software

T33.EPS

External Drawing

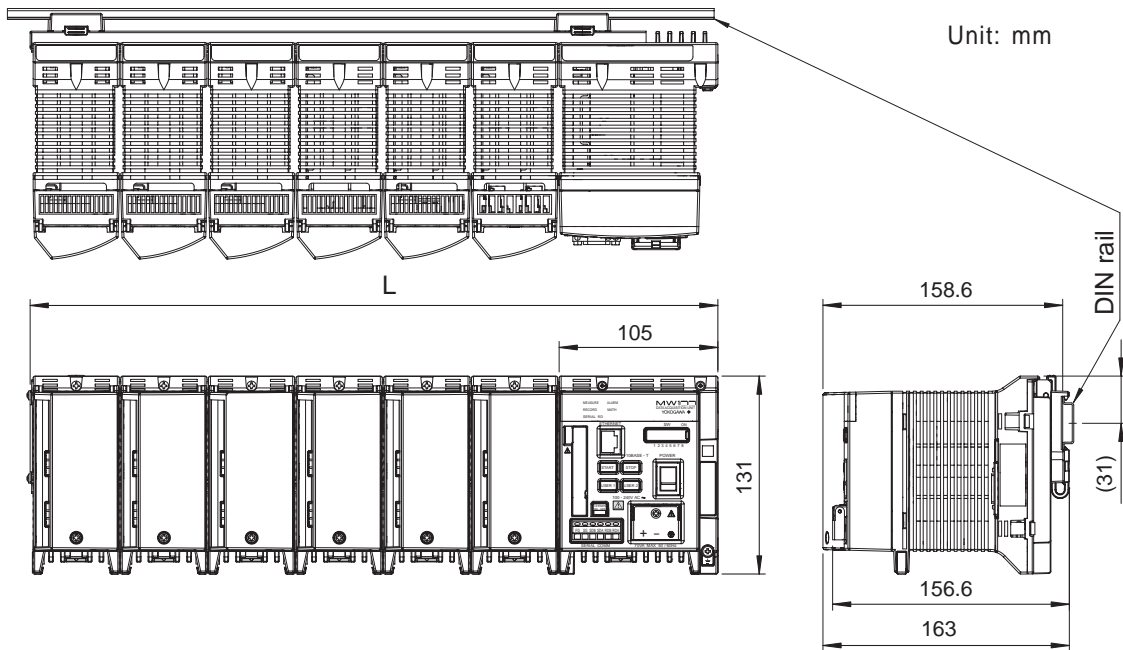

Number of equipped input/output modules	1	2	3	4	5	6
L	165	223	281	339	397	455

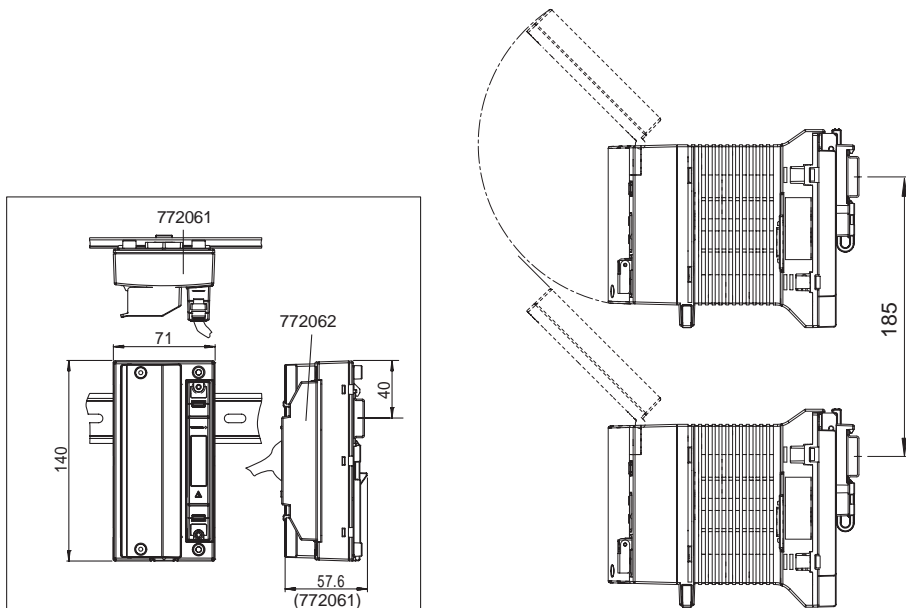

Dimension for installation in upper and lower directions using the DIN rail.

Caution when mounting the DIN rail:

Be sure to fix the DIN rail (such as screws) at three or more points including both ends of the equipment and the center. If it is fixed at two points or less, the equipment may bend.

DAQMASTER is a registered trademark of Yokogawa Electric Corporation.
 TCP/IP software of this product and documents on TCP/IP software were developed/created by Yokogawa Electric Corporation on the basis of BSD Networking Software (Release 1) licensed from University of California.
 Microsoft, MS, Windows, and Excel are registered trademarks of Microsoft Corporation in the United States.
 Lotus and 1-2-3 are registered trademarks of Lotus Development Corporation.
 MMX and Pentium are registered trademarks of Intel Corporation in the United States.
 Ethernet is a registered trademarks of XEROX Corporation.
 Java and Java-related trademarks are trademarks or registered trademarks of Sun Microsystems, Inc. in the United States and/or other countries.
 All other company and product names mentioned here are trademarks or registered trademarks of their respective companies.